

INSTRUCTION BOOK

**T H E Q U A D  
A M II T U N E R**



Scan by [www.valve-radio.co.uk](http://www.valve-radio.co.uk)



THE ACOUSTICAL MANUFACTURING CO., LTD.  
HUNTINGDON · HUNTS. · ENGLAND  
TELEPHONE: 2561/2 TELEGRAMS: ACOUSTICAL, HUNTINGDON

Issue 2/500/8/66

Scan by [www.valve-radio.co.uk](http://www.valve-radio.co.uk)

# INTRODUCTION

Although a VHF-FM service provides the highest possible quality of broadcast reproduction such transmissions are not available to all listeners since the reception range is normally limited to a maximum of 50 - 100 miles from the transmitter.

For areas where there is no VHF-FM service, or where reception over greater distances is required, the complementary AM service must be used.

Broadcast AM tuners may be divided into two groups according to their function; those intended for the high quality reproduction of programmes from a nearby transmitter, and those intended for acceptable reception of more distant transmitters.

The QUAD AMII tuner has been designed to perform either of these functions at the turn of a switch.

---

## DESCRIPTION

The QUAD AMII tuner is of the same style and size as the other QUAD control units and tuners. It is enclosed in a removable cover which permits mounting through a cabinet cut-out. Each unit is provided with leads for direct connection to the QUAD 22 or QCII control units from which the tuner power supply is taken. The leads, aerial, and earth connections are passed through the rear of the cover.

An aerial external to the tuner must be provided. Although the high sensitivity of the tuner allows the use of a short aerial, the best results will be obtained with a good aerial preferably of the vertical type.

A superheterodyne circuit is used with a tuned Radio Frequency amplifier stage. The Intermediate Frequency amplifier can be switched to provide either a narrow-band response or a wide-band response.

With the selectivity switch in the Wide position the IF amplifier allows an overall response to over 10kc/s and the RF amplifier ensures a very low level of receiver background noise. When reception conditions are suitable the quality of reproduction is comparable with that provided by a VHF-FM service.

In the Filter position of the selectivity switch the wide-band IF response remains available, but a rejection filter is included to eliminate the high pitched whistle generated by interaction of the received carrier and an adjacent channel carrier. The filter rejection is so narrow that it has little effect upon the quality of reproduction.

In the Narrow position of the selectivity switch the IF passband is reduced to improve separation between transmissions. This, with the RF amplifier, gives a tuner of high sensitivity, good selectivity, image rejection and automatic gain control characteristics. The overall response is equalised to 5kc/s and acceptable reproduction is obtained from distant transmitters despite the congested state of the broadcast bands.

Care has been taken to ensure the symmetry of the response in Wide and Narrow conditions and the tuning does not alter when switching from one to the other.

Because it is possible to obtain an accurate indication of tuning, either aurally or visually, only in the Narrow position, the luminous ribbon tuning indicator is made inoperative in the other two positions.

## CIRCUIT DETAIL

The aerial is transformer coupled to a variable- $\mu$  RF amplifier pentode (EF 89) the anode circuit of which is transformer coupled to the mixer grid. Both grid circuits are tuned on all wave-bands, and the Q of the medium wave circuits is reduced when switched to select a wide-band response.

A triode heptode (ECH 81) is used as the local oscillator and mixer. The oscillator anode circuit is tuned, and it is tracked by high-stability close-tolerance capacitors.

The 470kc/s output from the mixer anode is transformer coupled to the IF amplifier. The coupling is critical ( $Q_k=1$ ) in the narrow band condition. In the wide band condition the coupling is increased ( $Q_k=4$ ) by including a tertiary winding; this method ensures that the response remains symmetrical about the centre frequency.

The IF amplifier is the pentode section of a double diode pentode (EBF 89). This valve has a high slope combined with a low anode-grid capacitance. A simple fixed neutralising circuit is used further to reduce the effective anode-grid capacitance. This allows a high stage gain without tilting the response within the IF pass band.

One diode of the EBF 89, with a small delay voltage applied, is used to provide the AGC voltage. This voltage is applied fully to the RF and mixer stages, and partially to the IF stage. The AGC circuit provides good control and large input signals are accepted without overload.

The IF amplifier anode is transformer coupled to the diode signal rectifier. The loaded  $Q$  of this transformer is half that of the first IF transformer and the coupling is critical. In the wide-band condition the com-

bined IF response is within  $\pm 1\text{dB}$  to  $12\text{kc/s}$  and in the narrow-band condition it is  $-3\text{dB}$  at  $3.5\text{kc/s}$ . The narrow-band response is equalised to  $5\text{kc/s}$  by an audio frequency circuit. In the Filter position of the selectivity switch a bridged-T rejection circuit tuned to the adjacent channel heterodyne whistle is combined with the wide-band response.

The audio output is taken from a small fraction of the diode load in order to minimise distortion with heavily modulated input signals.

The tuning indicator (EM 84) has a variable- $\mu$  characteristic and will give a clear indication of the correct tuning point over a wide range of input signal levels. The greatest accuracy of indication is given when the IF amplifier has a narrow pass band. The indicator is therefore made inoperative in the wide-band switch positions.

# INSTALLATION

## MOUNTING

The tuner may be mounted in a cabinet panel of any thickness up to  $\frac{3}{4}$ " (20mm).

A 10" x 3  $\frac{1}{16}$ " (254 x 78mm.) opening with  $\frac{1}{4}$ " (6mm.) radius corners should be cut in the panel.

Remove the two screws from the rear of the cover and slide the cover off.

Insert tuner, leads first, into the cut-out from the front. The lugs on the rear of the tuner front panel should locate inside the cut-out.

Replace the cover from the rear, making sure that the leads are not trapped. Insert the two screws and tighten until the tuner is just held in position, then give one additional turn to lock securely.

## LT/HT AND SIGNAL LEAD CONNECTIONS

The mains supply to the amplifier must be switched off before connecting or disconnecting the tuner leads.

The LT/HT lead (terminated by a four pin plug) and the Signal lead (terminated by a co-axial plug) may

now be connected to the appropriate sockets of the QUAD 22 or QC II control unit. The control unit Instruction Book will show the arrangements possible.

## AERIAL

The QUAD AM II tuner will work from any aerial, but for the best signal/noise ratio a good aerial is worth the trouble of installation. A vertical aerial is most effective, and its down-lead should be spaced away from the building. Where heavy local interference (e.g. that generated by electrical machinery) is troublesome the anti-static type of aerial, with matching transformers and a screened down lead, may be used. In order to choose the most suitable aerial a knowledge of local reception conditions is necessary and the advice of your dealer should be sought.

The aerial lead should be connected to the red Aerial socket with the red 4mm plug provided.

## EARTH

A direct connection to a buried earth, or metallic rising water main, will give better results than the

Scan by [www.valve-radio.co.uk](http://www.valve-radio.co.uk)

electricity supply earthed third wire. Your dealer should test the efficiency of the earth lead, and the apparatus must not be connected to the mains without an efficient earth connection.

The earth lead should be connected to the E terminal on the control unit and this connection will serve to earth the whole installation. If an anti-static aerial is used the aerial (red) and earth (black) sockets on the tuner should be used to connect the aerial in the way recommended by the manufacturers. The control unit earth is still used to make the normal external earth connection.

## USE WITH OTHER AMPLIFIERS AND CONTROL UNITS

If the tuner is used with other makes of amplifier it may be necessary to change the LT/HT and Signal plugs.

The LT/HT lead contains three wires which should be connected to the following voltages :

Green :	} 6.3 Volts (L.T.) centre-tapped to earth.
Black :	
Red :	Between 250 and 350 Volts positive DC (HT)

The current drawn from the LT is 1.2 amps, and from the HT is 35 milli-amps.

The screen of the co-axial Signal lead is both HT negative and earth. The signal output is carried on the centre conductor of this lead.

The nominal audio output of the Tuner is 100 millivolts r.m.s. (for a 30% modulated carrier) and the amplifier used should give full output for this voltage. The input resistance of the amplifier should not be less than 100,000 ohms.

# OPERATION

## CONTROLS

There are three controls : Tuning, wave-band switch, and selectivity switch.

## TUNING

Set selectivity switch to the Narrow position so that the tuning indicator lights. After selecting the correct wave-band, tune in the wanted transmission. Adjust the tuning until the shadow between the two luminous bands of the indicator is at a minimum.

Accurate tuning cannot be obtained in the Filter or Wide positions of the selectivity switch, and the tuning indicator is therefore made inoperative in these positions.

Always switch to Narrow before tuning.

## LOCAL STATION RECEPTION

Turn the selectivity switch to the Wide position in order to accept the full transmitted frequency range. If a high-pitched whistle is heard this may be eliminated by switching to the Filter position.

Sometimes, too, adjacent channel interference experienced in the Filter or Wide positions can be reduced by detuning slightly away from the interfering transmission, without greatly affecting the wanted signal. Under these conditions such detuning may well result in an overall improvement of reception.

(It should be noted, however, that the true tuning position remains unaffected in spite of this audible improvement which is also accompanied by some reduction in high frequency response and apparent increased volume due to reduction of the AGC voltage).

## DISTANT STATION RECEPTION

The Narrow selectivity position will normally give the more acceptable results although, if reception conditions are good, better quality may be obtainable in the Filter position.

If reception is very poor a considerable improvement may be effected by use of the 5K variable slope filter on the Control Unit.



## ALIGNMENT INSTRUCTIONS

**Each set is fully aligned before despatch and this procedure is intended only for subsequent re-alignment should it become necessary. No departure from this procedure is permissible and the work should be undertaken only by a competent radio service engineer.**

### AF ALIGNMENT

Power supplies are not required for this adjustment and the tuner should not be connected to the control unit.

Connect an AF signal generator between the junction C41,R20 and earth. Connect a sensitive AC valve voltmeter or oscilloscope across tuner output plug (PL1). Adjust signal generator to give about 10 volts at exactly 9 kc/s (or 10 kc/s on Overseas tuners). With selectivity switch to Filter adjust L10 and RV1 for minimum output (to be less than 5mV). Lock RV1.

*Page Eight*

### IF ALIGNMENT

Preliminary. Plug audio lead into control unit, then HT/LT lead. Wave-change switch to SW (or SW2 on Overseas tuners). Selectivity switch to Narrow. Tuning capacitor to maximum capacity. Short-circuit C29. Short-circuit C31. Short-circuit C33. Connect 0-50  $\mu$ A DC meter in series with R23. Unscrew the IF transformer tuning cores until they project slightly from the former.

The correct tuning point is the first one reached when the core is screwed in.

Scan by [www.valve-radio.co.uk](http://www.valve-radio.co.uk)

During the IF and RF alignment the output of the RF signal generator should be adjusted to produce about half scale deflection of the output current microammeter.

A damping resistor of 10,000 ohms is used during the alignment procedure. The HT supply should be switched off when handling this resistor.

- (1) Apply 470 kc/s signal to EBF89 grid (V3 pin 2). Connect damping resistor across IFT2 primary. Adjust IFT2 secondary (top core) for maximum output current.
- (2) Transfer damping resistor to IFT2 secondary. Adjust IFT2 primary (bottom core) for maximum output current.
- (3) Repeat (1) and (2) until there is no further improvement in output.
- (4) Apply 470 kc/s signal to ECH81 grid (V2 pin 2). Connect damping resistor across IFT1 primary. Adjust IFT1 secondary (top core) for maximum output current.
- (5) Transfer damping resistor to IFT1 secondary. Adjust primary (bottom core) for maximum output current.
- (6) Repeat (4) and (5) until there is no further improvement in output.

- (7) Remove damping resistor. Check that response curve is symmetrical either side of 470 kc/s.
- (8) With selectivity switch to Wide check that output current is equal at 459, 470 and 481 kc/s, and that a rise of about 10% appears at 465 and 475 kc/s.

## RF ALIGNMENT (EUROPEAN TUNERS)

Preliminary. Remove short-circuit from C29. Check that pointer lies at 588m when tuning capacitor is at maximum. Selectivity switch to Narrow. Connect RF signal generator to Aerial and Earth sockets via dummy aerial. The correct tuning point for L1, L2, L4, L5, L7, L8 is with the core nearest the mounting base of the coil.

- (1) Switch to LW. Set tuner to 2,000 m and signal generator to 150 kc/s. Adjust core of L7, then L4, then L1 for maximum output current.
- (2) Set tuner to 1,000 m and signal generator to 300 kc/s. Adjust C25, then C11, then C1 for maximum output current.
- (3) Repeat (1) and (2) until there is no improvement in output current.

- (4) Switch to MW. Set tuner to 525m and signal generator to 572 kc/s. Adjust core of L8, then L5, then L2 for maximum output current.
- (5) Set tuner to 200m and signal generator to 1,500 kc/s. Adjust C26, then C12, then C2 for maximum output current.
- (6) Repeat (4) and (5) until there is no improvement in output current. Finish on (5).
- (7) Set signal generator to 1,000 kc/s, tune in signal and check that calibration is correct (300 m).
- (8) Switch to SW. Set tuner to 6.5 mc/s and signal generator to 6.5 mc/s. Adjust L9, then L6, then L3 for maximum output current. Set signal generator to 7.44 mc/s, increase signal generator output and check that image frequency is received with tuner set to 6.5 mc/s.
- (9) Set tuner to 17 mc/s and signal generator to 17 mc/s. Adjust C27, then C13, then C3 for maximum output current. Alignment of C13 and C3 may be assisted by rocking the ganged capacitor slightly. Set signal generator to 17.94 mc/s, increase signal generator output and check that image frequency is received with tuner set to 17 mc/s.
- (10) Repeat (8) and (9) until there is no improvement in output current. Finish on (9).
- (11) Set signal generator to 12 mc/s, tune in signal, and check that calibration is correct.
- (12) Remove micro-ammeter and reconnect R23. Remove short-circuit from C31 and C33.

## RF ALIGNMENT (OVERSEAS TUNERS)

Preliminary. Remove short-circuit from C29. Check that pointer lies at 510 kc/s when tuning capacitor is at maximum. Selectivity switch to Narrow. Connect RF signal generator to Aerial and Earth sockets via dummy aerial. The correct tuning point for L2, L5, L8, L11, L12, L13 is with the core nearest the mounting base of the coil.

- (1) Switch to MW. Set tuner to 572 kc/s (this coincides with the 6.5 mc/s mark on the SW2 scale). Set signal generator to 572 kc/s. Adjust core of L8, then L5, then L2 for maximum output current.
- (2) Set tuner and signal generator to 1,500 kc/s. Adjust C25, then C11, then C1 for maximum output current.

- (3) Repeat (1) and (2) until there is no improvement in output current. Finish on (2).
- (4) Set signal generator to 1,000 kc/s, tune in signal and check that calibration is correct.
- (5) Switch to SW1. Set tuner and signal generator to 2.5 mc/s. Adjust core of L13, then L12, then L11 for maximum output current.
- (6) Set tuner and signal generator to 6.25 mc/s. Adjust C26, then C12, then C2 for maximum output current.
- (7) Repeat (5) and (6) until there is no improvement in output current. Finish on (6).
- (8) Set signal generator to 4.0 mc/s, tune in signal and check that calibration is correct.
- (9) Switch to SW2. Set tuner to 6.5 mc/s and signal generator to 6.5 mc/s. Adjust L9, then L6, then L3 for maximum output current. Set signal generator to 7.44 mc/s, increase signal generator output and check that image frequency is received with tuner set to 6.5 mc/s.
- (10) Set tuner to 17 mc/s and signal generator to 17 mc/s. Adjust C27, then C13, then C3 for maximum output current. Alignment of C13 and C3 may be assisted by rocking the ganged capacitor slightly. Set signal generator to 17.94 mc/s, increase signal generator output and check that image frequency is received with tuner set to 17 mc/s.
- (11) Repeat (9) and (10) until there is no improvement in output current. Finish on (10).
- (12) Set signal generator to 12 mc/s, tune in signal, and check that calibration is correct.
- (13) Remove micro-ammeter and reconnect R15. Remove short-circuit from C31 and C33.

# SPECIFICATION

Tuning range :	AMII/European
	Long wave : 2070—800 metres (145—375 kc/s)
	Medium wave : 588—185 metres (510—1620 kc/s)
	Short wave : 5.8—18.5 mc/s (32—16.2 metres)
	AMII/Overseas
	Medium wave : 510—1620 kc/s (588—185 metres)
	Short wave 1 : 2.2—6.6 mc/s (136—45 metres)
	Short wave 2 : 5.8—18.5 mc/s (32—16.2 metres)
Output level :	100mV (Nominal for 30% modulation)
Output resistance :	15,000 ohms
Filter rejection frequency :	AMII/European : 9kc/s AMII Overseas : 10kc/s
Power requirement :	HT 35mA at 330V. LT 1.2 A at 6.3V.
Power and Signal cable lengths :	40" (1m)
Valve complement :	EF 89, ECH 81, EBF 89, EM 84
Front panel :	Silvered Fawn
Knobs :	Matt Brown
Dimensions :	10½" x 3½" x 6" (267 x 89 x 153 mm)
Weight :	6 lbs. (2.7 Kg.)

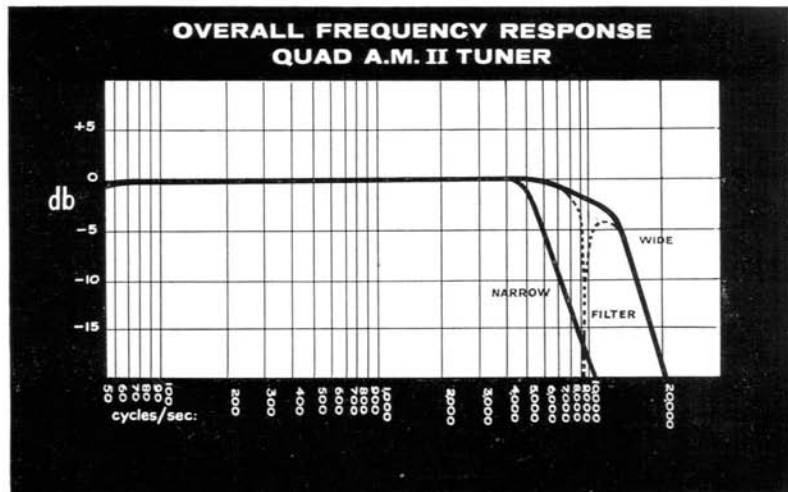

B 11489

R	1	2	3	4	5	6	7	8	9	10	11	12	13	14	15	16	17	18	19	20	21	22	23	24	25	26	27	28	R																
C	1	4	5	6	7	8	9	10	11	12	13	14	15	16	17	18	19	20	21	22	23	24	25	26	27	28	29	30	31	32	33	34	35	36	37	38	39	40	41	42	43	44	45	46	C

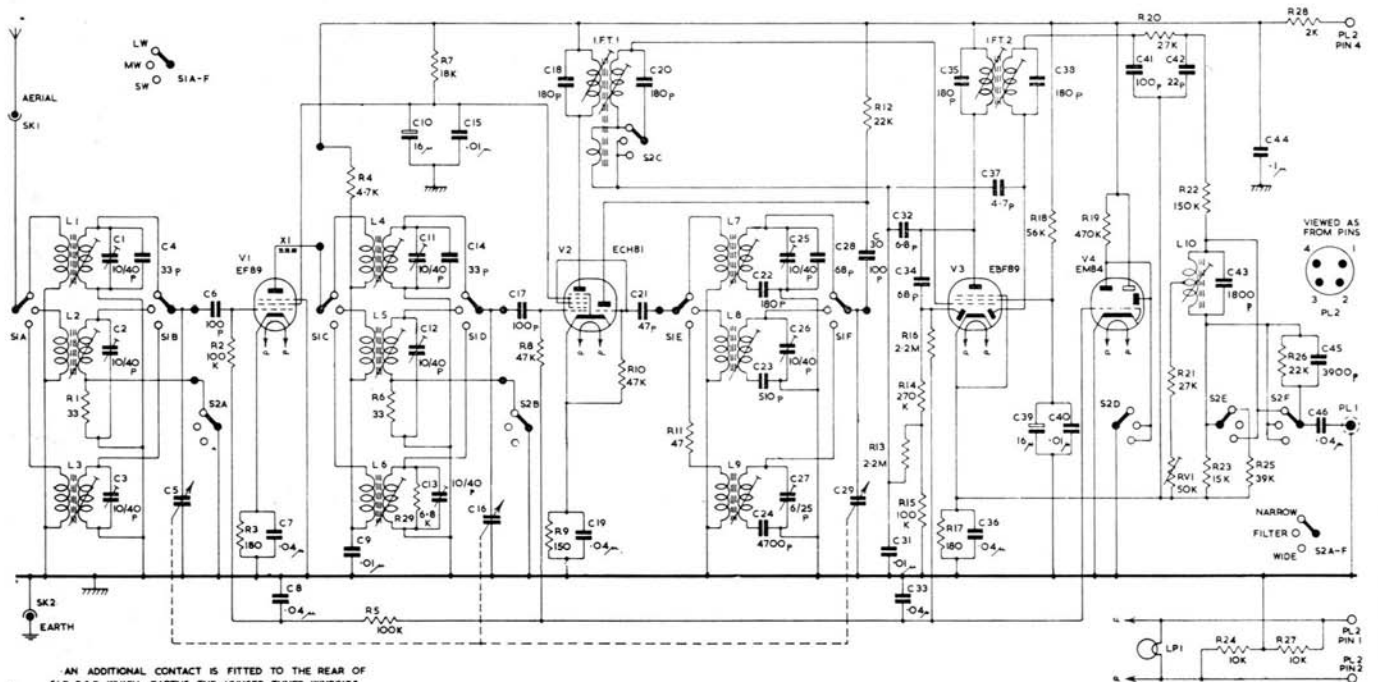

B 11539

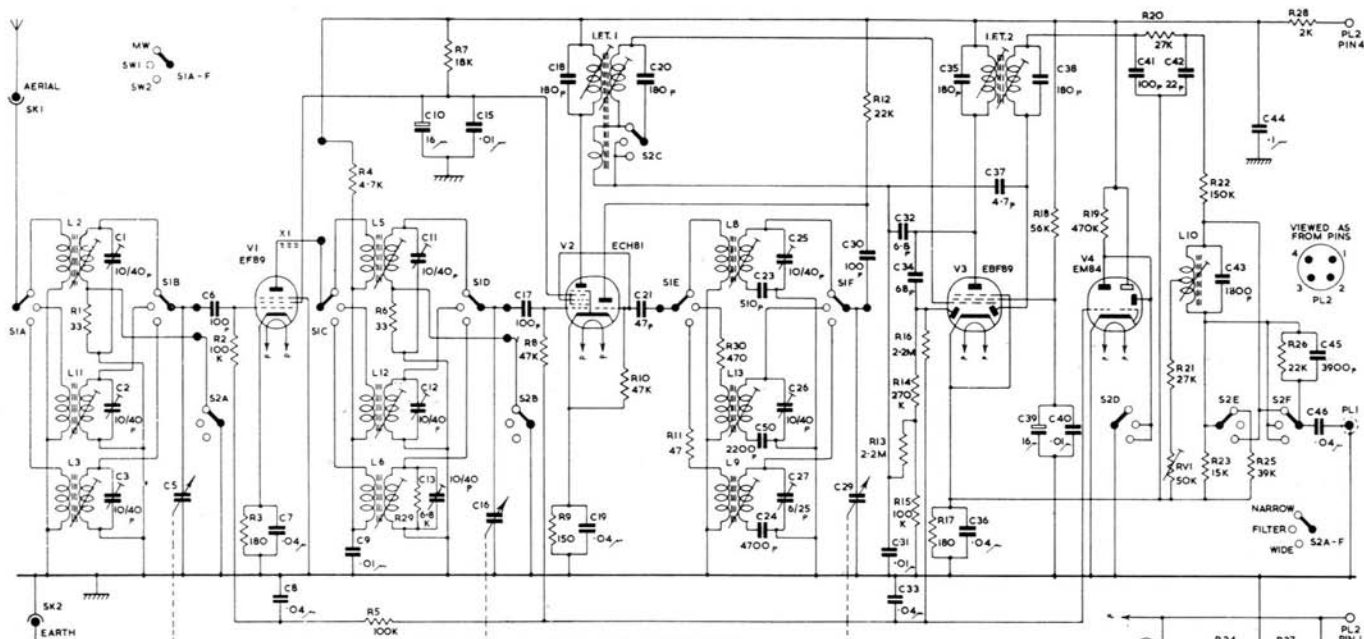
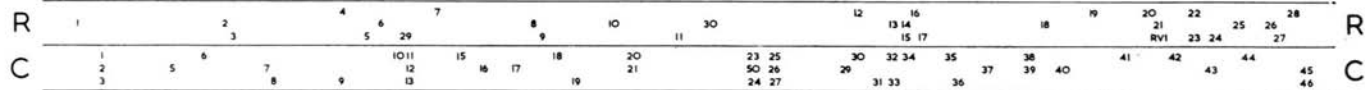

AN ADDITIONAL CONTACT IS FITTED TO THE REAR OF S1B, D & E WHICH EARTHS THE UNUSED TUNED WINDINGS.

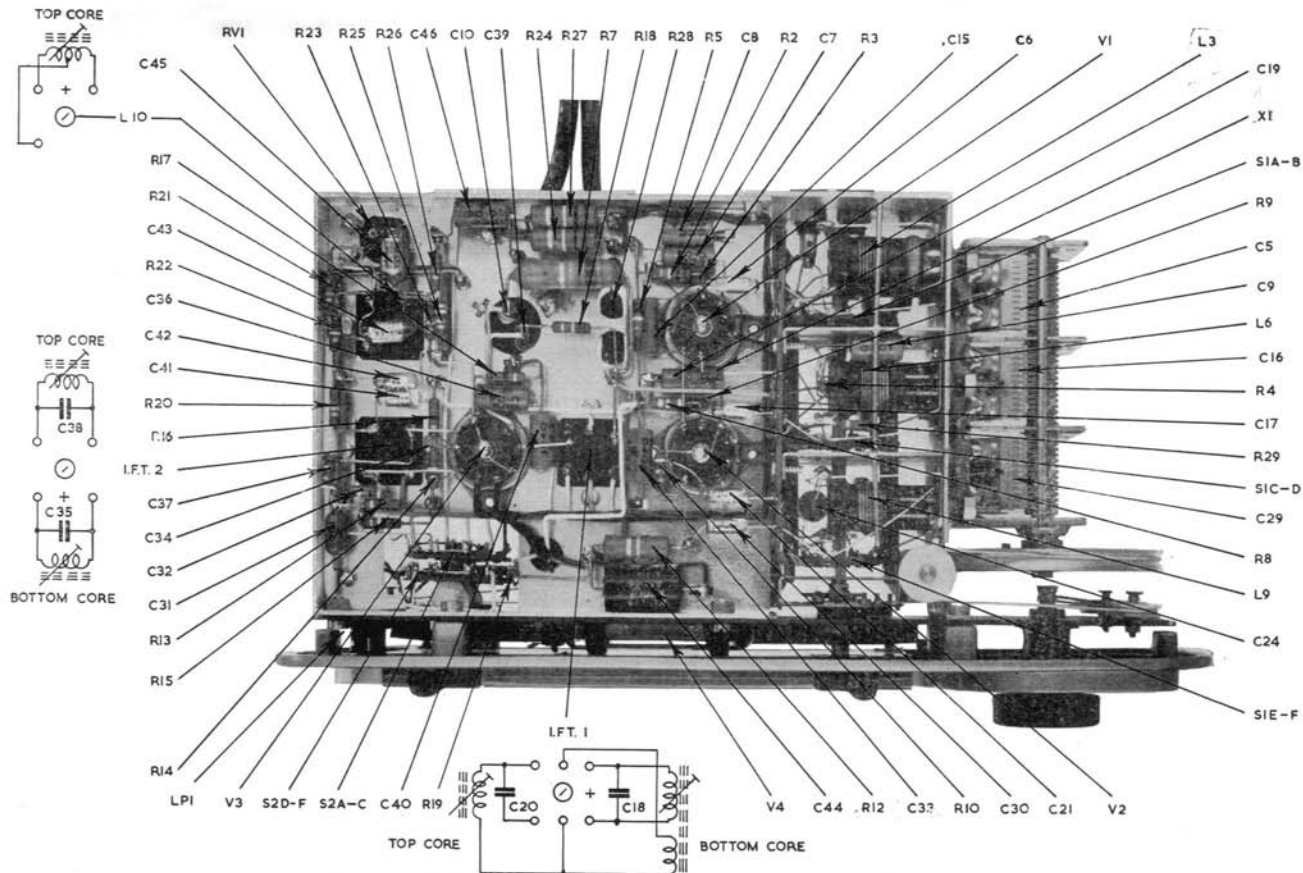



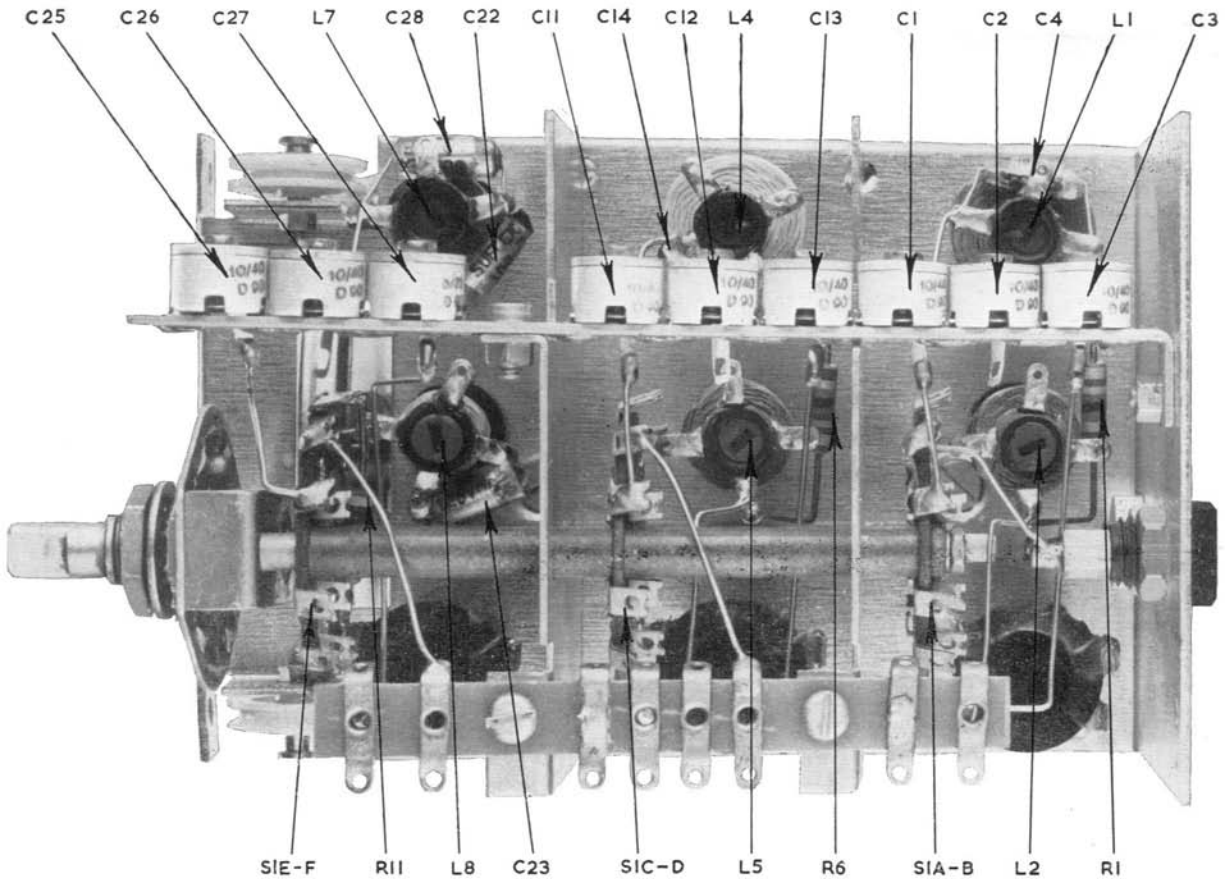

LAYOUT PHOTOGRAPH B — RF CHASSIS (EUROPEAN)

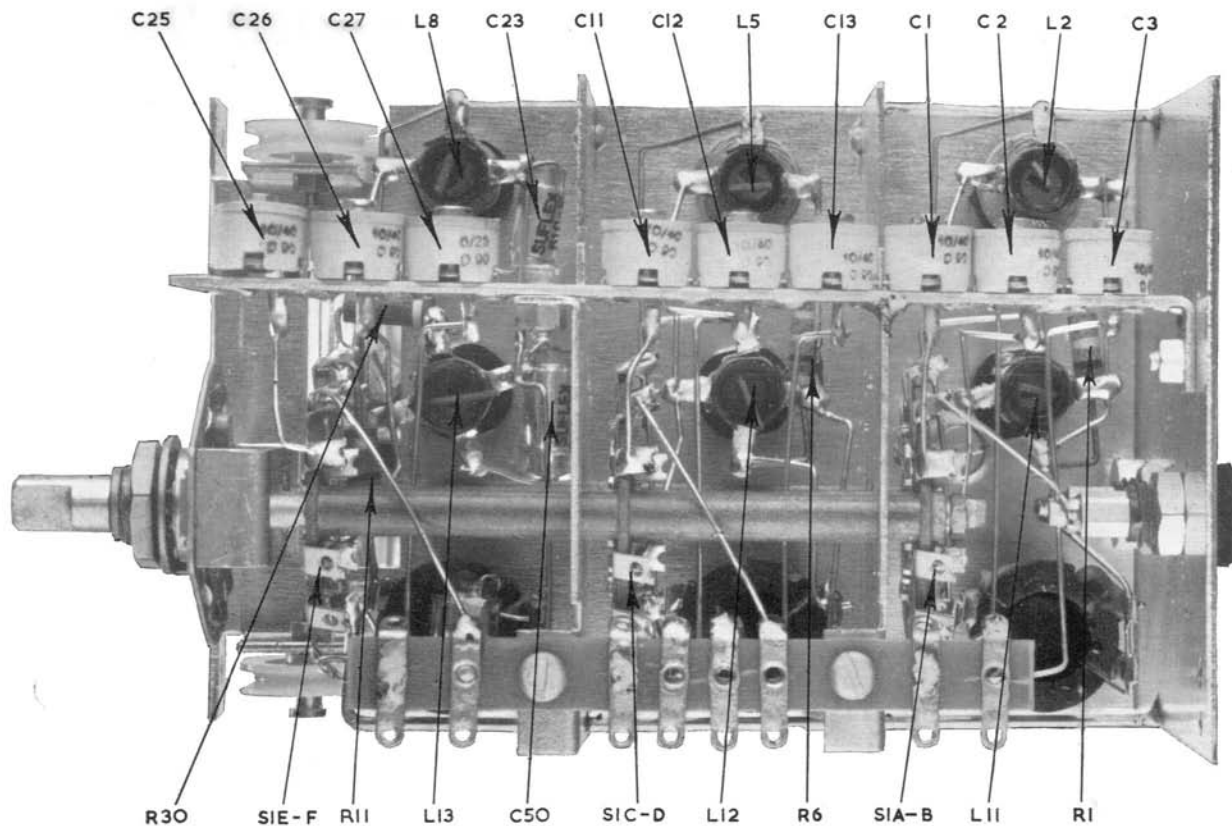

LAYOUT PHOTOGRAPH C — RF CHASSIS (OVERSEAS)

The drive cord runs from the upper pulley to the rear of the slow motion drive capstan, then  $2\frac{1}{2}$  turns around the capstan in a forward direction, and off to the lower pulley.

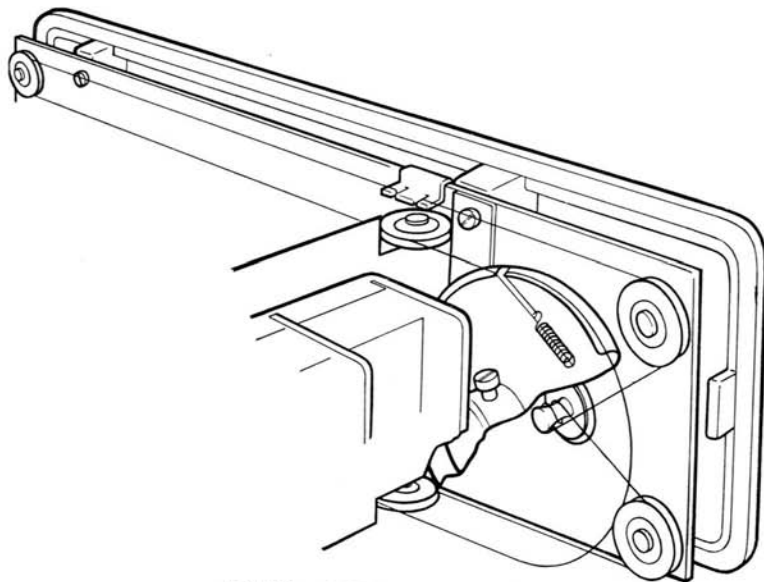

DRIVE CORD ASSEMBLY

## AM II TUNER COMPONENTS LIST

Component Reference	Value	Tolerance	Makers Reference	Stock No.	Layout Photograph
R1	33	± 10%	Dubilier BTS	314/A	BC
R2	100K	± 10%	Dubilier BTS	200/A	A
R3	180	± 10%	Dubilier BTS	290/B	A
R4	4.7K	± 10%	Dubilier BTS	240/F	A
R5	100K	± 10%	Dubilier BTS	200/A	A
R6	33	± 10%	Dubilier BTS	314/A	BC
R7	18K	± 10%	Erie 10AD	220/A	A
R8	47K	± 10%	Dubilier BTS	208/F	A
R9	150	± 10%	Dubilier BTS	295/A	A
R10	47K	± 10%	Dubilier BTS	208/F	A
R11	47	± 10%	Dubilier BTS	310/C	BC
R12	22K	± 10%	Dubilier BTA	217/B	A
R13	2.2M	± 10%	Dubilier BTS	157/D	A
R14	270K	± 10%	Dubilier BTS	185/D	A
R15	100K	± 10%	Dubilier BTS	200/A	A
R16	2.2M	± 10%	Dubilier BTS	157/D	A
R17	180	± 10%	Dubilier BTS	290/B	A
R18	56K	± 10%	Dubilier BTS	206/A	A
R19	470K	± 10%	Dubilier BTS	176/C	A
R20	27K	± 10%	Dubilier BTS	210/D	A
R21	27K	± 10%	Dubilier BTS	210/D	A
R22	150K	± 10%	Dubilier BTS	202/C	A
R23	15K	± 10%	Dubilier BTS	224/C	A
R24	10K	± 10%	Dubilier BTA	230/F	A
R25	39K	± 10%	Dubilier BTS	208/M	A
R26	22K	± 10%	Dubilier BTS	217/A	A

Component Reference	Value	Tolerance	Makers Reference	Stock No.	Layout Photograph
R27	10K	$\pm 10\%$	Dubilier BTA	230/F	A
R28	2K	$\pm 10\%$	Painton P306	252/A	A
R29	6.8K	$\pm 10\%$	Dubilier BTS	235/B	A
R30†	470	$\pm 10\%$	Dubilier BTS	270/E	C
RV1	50K Lin		Egen 123	385/A	A
C1	10/40p		Steatite 10 S—Triko O7 10/40 D90	554/N	BC
C2	10/40p		Steatite 10 S—Triko O7 10/40 D90	554/N	BC
C3	10/40p		Steatite 10 S—Triko O7 10/40 D90	554/N	BC
C4*	33p	$\pm 5\%$	Suflex HS 12/K	537/A	B
C5	528p Max		Acoustical Drg. No. A 11490 Iss. I with C16 & C29	554/A	A
C6	100p	$\pm 10\%$	Suflex HS 12/L	528/A	A
C7	.04 $\mu$	$\pm 20\%$	Dubilier 400 150 V Wkg.	501/B	A
C8	.04 $\mu$	$\pm 20\%$	Dubilier 400 150 V Wkg.	501/B	A
C9	.01 $\mu$	$\pm 20\%$	Dubilier 400 400 V Wkg.	506/E	A
C10	16 $\mu$		Hunts. KD413 with C39	469/D	A
C11	10/40p		Steatite 10 S—Triko O7 10/40 D90	554/N	BC
C12	10/40p		Steatite 10 S—Triko O7 10/40 D90	554/N	BC
C13	10/40p		Steatite 10 S—Triko O7 10/40 D90	554/N	BC
C14*	33p	$\pm 5\%$	Suflex HS 12/K	537/A	B
C15	.01 $\mu$	$\pm 20\%$	Dubilier 400 400 V Wkg.	506/E	A
C16	528pMax		See C5	—	A
C17	100p	$\pm 10\%$	Suflex HS 12/L	528/A	A
C18	180p	$\pm 2\%$	Suflex HS 12/L (Part of I.F.T.1)	527/N	A
C19	.04 $\mu$	$\pm 20\%$	Dubilier 400 150 V Wkg.	501/B	A

Component Reference	Value	Tolerance	Makers Reference	Stock No.	Layout Photograph
C20	180p	± 2%	Suflex HS 12/L (Part of I.F.T. 1)	527/N	A
C21	47p	± 10%	Suflex HS 12/K	534/B	A
C22*	180p	± 2%	Suflex HS 12/L	527/N	B
C23	510p	± 2%	Suflex HS 12/F	521/M	BC
C24	4700p	± 5%	Suflex HS 15/F	512/A	A
C25	10/40p		Steatite 10 S—Triko O7 10/40 D90	554/N	BC
C26	10/40p		Steatite 10 S—Triko O7 10/40 D90	554/N	BC
C27	6/25p		Steatite 10 S—Triko O7 6/25 D90	554/M	BC
C28*	68p	± 5%	Suflex HS 12/L	529/B	B
C29	528p Max		See C5	—	A
C30	100p	± 10%	Suflex HS 12/L	528/A	A
C31	.01 μ	± 20%	Dubilier 4C0 150 V Wkg.	506/D	A
C32	6.8p	± .5p	Erie P100A	547/A	A
C33	.04 μ	± 20%	Dubilier 400 150 V Wkg.	501/B	A
C34	68p	± 5%	Suflex HS 12/L	529/B	A
C35	180p	± 2%	Suflex HS 12/L (Part of I.F.T. 2)	527/N	A
C36	.04 μ	± 20%	Dubilier 400 150 V Wkg.	501/B	A
C37	4.7p	± .5p	Erie P100A	548/A	A
C38	180p	± 2%	Suflex HS 12/L (Part of I.F.T.2)	527/N	A
C39	16 μ		See C10	—	A
C40	.01 μ	± 20%	Dubilier 400 400 V Wkg.	506/E	A
C41	100p	± 10%	Suflex HS 12/L	528/A	A
C42	22p	± 1p	Suflex HS 12/K	543/A	A
C43	1800p	± 5%	Suflex HS 15/E	515/G	A
C44	.1 μ	± 20%	Hunts. AM 108	495/A	A
C45	3900p	± 5%	Suflex HS 15/F	513/M	A
C46	.04 μ	± 20%	Dubilier 400 150 V Wkg.	501/B	A

Component Reference	Value	Tolerance	Makers Reference	Stock No.	Layout Photograph
C50†	2200p	± 5%	Suflex HS 12/G	514/M	C
L1*			L.W. Aerial Coil	749/P	B
L2			M.W. Aerial Coil	749/Q	BC
L3			S.W. Aerial Coil*/S.W.2 Aerial Coil†	749/N	A
L4*			L.W. R.F. Coil	749/S	B
L5			M.W. R.F. Coil	749/T	BC
L6			S.W. R.F. Coil*/S.W.2 R.F. Coil†	749/O	A
L7*			L.W. Oscillator Coil	749/V	B
L8			M.W. Oscillator Coil	749/W	BC
L9			S.W. Oscillator Coil*/S.W.2 Oscillator Coil†	749/M	A
L10			Filter Coil Acoustical Drg. No. A11506 Iss.1	749/L	A
L11†			S.W.1 Aerial Coil	749/R	C
L12†			S.W.1 R.F. Coil	749/U	C
L13†			S.W.1 Oscillator Coil	749/X	C
I.F.T.1			Acoustical Drg. No. A11193 Iss.1	749/J	A
I.F.T.2			Acoustical Drg. No. A11477 Iss.2	749/K	A
X1			Ferrite Bead Mullard FX 1242	442/A	A
V1			Mullard EF89		A
V2			Mullard ECH81		A
V3			Mullard EBF89		A
V4			Mullard EM84		A

Component Reference	Value	Tolerance	Makers Reference	Stock No.	Layout Photograph
LP1			6.3v ·115A Osram OS76 11mm MES Round	690/J	A
S1A-F S2A-F			Acoustical Drg. No. M11478 Iss.2 Acoustical Drg. No. A11496 Iss.2	661/O 661/P	ABC A

\* Used on European Tuner only

† Used on Overseas Tuner only.

Scan by [www.valve-radio.co.uk](http://www.valve-radio.co.uk)

*Page Twenty-three*



10" (254 mm)

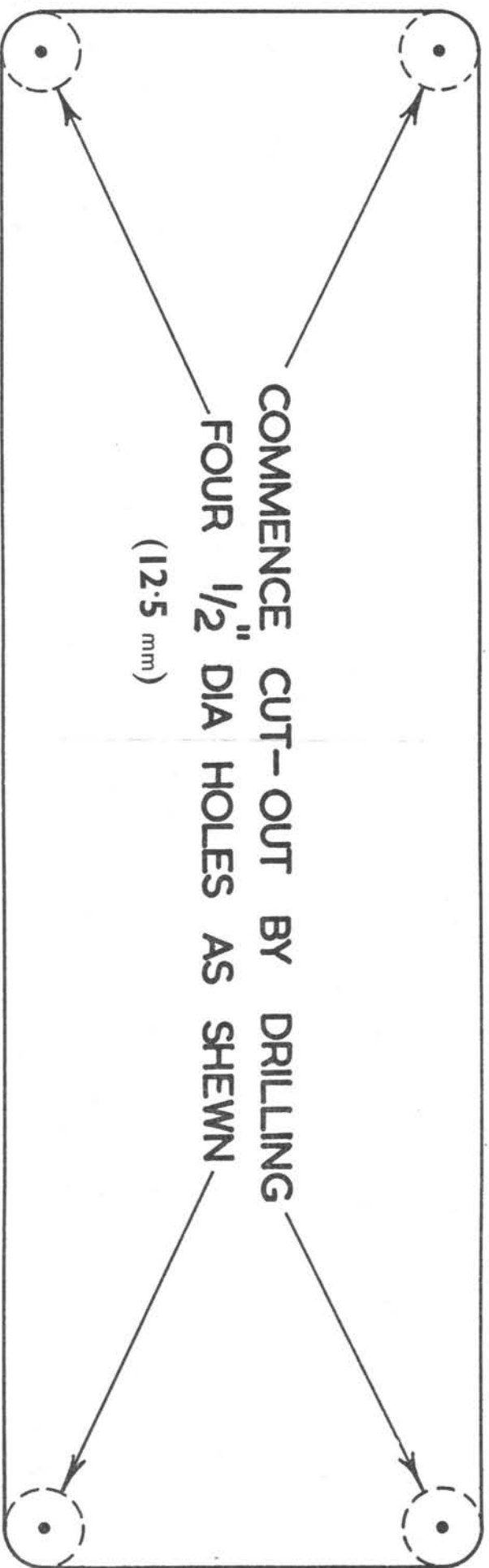

$3\frac{1}{16}$ "

(78 mm)

COMMENCE CUT-OUT BY DRILLING

FOUR  $\frac{1}{2}$ " DIA HOLES AS SHEWEN

(12.5 mm)

CUT-OUT TEMPLATE FOR QUAD CONTROL UNITS & TUNERS