

QUAD AM 3 TUNER

instruction booklet

The Acoustical Manufacturing Co. Ltd
St Peters Road, Huntingdon, Hunts, England
Telephone: 2561/2 Telegrams: Acoustical, Huntingdon

Iss 2 1M1270

1

Contents

Aerial	6
Alignment Instructions—AF	11
—IF	11
—RF (European model)	12
—RF (Overseas model)	13
Audio output	4
Circuit Detail	10
Components lists (see circuit diagrams)	19
Connections	4
Description	3
Earth	8
Fuse	4
Guarantee	20
Installation	4
Introduction	3
Local and Distant reception	10
Mains supply	4
Mains voltage adjustment	4
Maintenance	11-19
Mounting	4
Operation	10
Specification	20
Tuning	10
Use with other amplifiers	8

2

Illustrations

Rear panel view	1
Aerials	2-7
Circuit diagrams—European model	
—Overseas model	
Front panel view	8
Above chassis view	9
Under chassis view	10
RF Chassis—European model	11
—Overseas model	12
Replacing the drive cord	13

INTRODUCTION

Although a VHF/FM service provides the highest possible quality of broadcast reproduction such transmissions are not available to all listeners, since the reception range is usually under 100 miles and even less with stereo broadcasts. Where a VHF/FM service is not available, AM on Long, Medium or Short wavebands must be used and in many parts of the world this also means a loss of quality due to poor reception conditions and the overcrowded state of some wavebands, except where the powerful signal of a local transmitter permits a quality comparable with that of VHF/FM.

AM reception thus falls into two categories :

- (i) high quality reproduction under the latter conditions, requiring a wide bandwidth, and
- (ii) extracting the best signal possible under difficult conditions necessitating a narrow bandwidth.

The Quad AM3 provides for both conditions at the turn of a switch and in addition there is a filter for removing the adjacent channel heterodyne whistle.

The AM3 is a self-powered unit primarily intended for use with the Quad 33/303 amplifier but it may be used with other amplifiers if required.

Description

A superheterodyne circuit is used with a tuned radio frequency amplifier stage. The intermediate frequency amplifier can be switched to provide either a narrow-band response or a wide-band response.

With the selectivity switch in the 'Wide' position the IF

amplifier allows an overall response to over 10 kHz and the RF amplifier ensures a very low level of receiver background noise. When reception conditions are suitable the quality of reproduction is comparable with that provided by a VHF/FM service.

In the 'Filter' position of the selectivity switch the wide-band IF response remains but a rejection filter is included to eliminate the high pitched whistle generated by interaction of the received carrier with an adjacent channel carrier. The filter rejection is so narrow that it has little effect upon the quality of reproduction.

In the 'Tune' position of the selectivity switch the IF passband is reduced to improve separation between transmissions. This, with the RF amplifier, gives a tuner of high sensitivity, good selectivity and image rejection, and improved automatic gain control characteristics, and acceptable reproduction is obtained from distant transmitters despite the congested state of the broadcast bands.

A tuning indicator is provided of the luminous ribbon type which gives a clear indication of the correct tuning point in the 'Tune' switch position. The receiver tuning does not alter when the selectivity switch is changed so that the tuning indicator is made inoperative in the 'Wide' and 'Filter' positions.

As with other Quad units, the AM3 is enclosed in a removable metal cover which permits mounting through a cabinet cut-out. The mains fuse and voltage adjustment are mounted on the rear panel together with the aerial and earth sockets and the mains and audio output connectors.

An external aerial should be used, preferably erected out of doors as clear of buildings as possible (see Aerial page 7).

INSTALLATION

Mounting

The tuner may either be used free standing or mounted in a cabinet panel of up to $\frac{3}{4}$ ".

In the latter case cut a rectangular aperture 10" x 3" approximately, in the panel using the template in the rear of this booklet.

Remove the two screws from the rear of the cover and slide the cover off.

Insert the tuner, leads first, into the aperture from the front, ensuring that the lugs on the rear of the tuner front panel locate inside the aperture.

Replace the cover from the rear making sure that the leads are not trapped. Insert the two screws and tighten until the tuner is just held in position and then give one additional half turn to each screw to lock securely.

Mains Voltage

Ensure that the mains voltage adjustment at the rear of the tuner is correctly set for your supply voltage. If it is not, withdraw the cap until its pins just clear the socket, rotate it to the correct setting and push it firmly home again.

Connections

The tuner is supplied with leads and plugs for direct connection to the Quad 33 control unit. For use with other amplifiers see separate section under this heading.

Mains

The plug with the two flat pins should be inserted into one of the two corresponding sockets at the rear of the Quad 33 control unit, whose on/off switch will then also control the supply to the tuner. Similar outlets at the rear of the AM3 provide for further mains distribution to another tuner, electrostatic speakers, etc.

The fuse is a 20 x 5 mm anti-surge type rated at 160mA and should be replaced only by one of similar rating. Note that the double mains outlet socket is *not* protected by this fuse.

Audio Output. The output lead terminates in a 5-pin DIN plug wired :

pin 1	Blank
pin 4	Blank
pin 2	Screen
pin 3	Output
pin 5	Output

This plug should be inserted into the Radio 2 socket at the rear of the control unit.

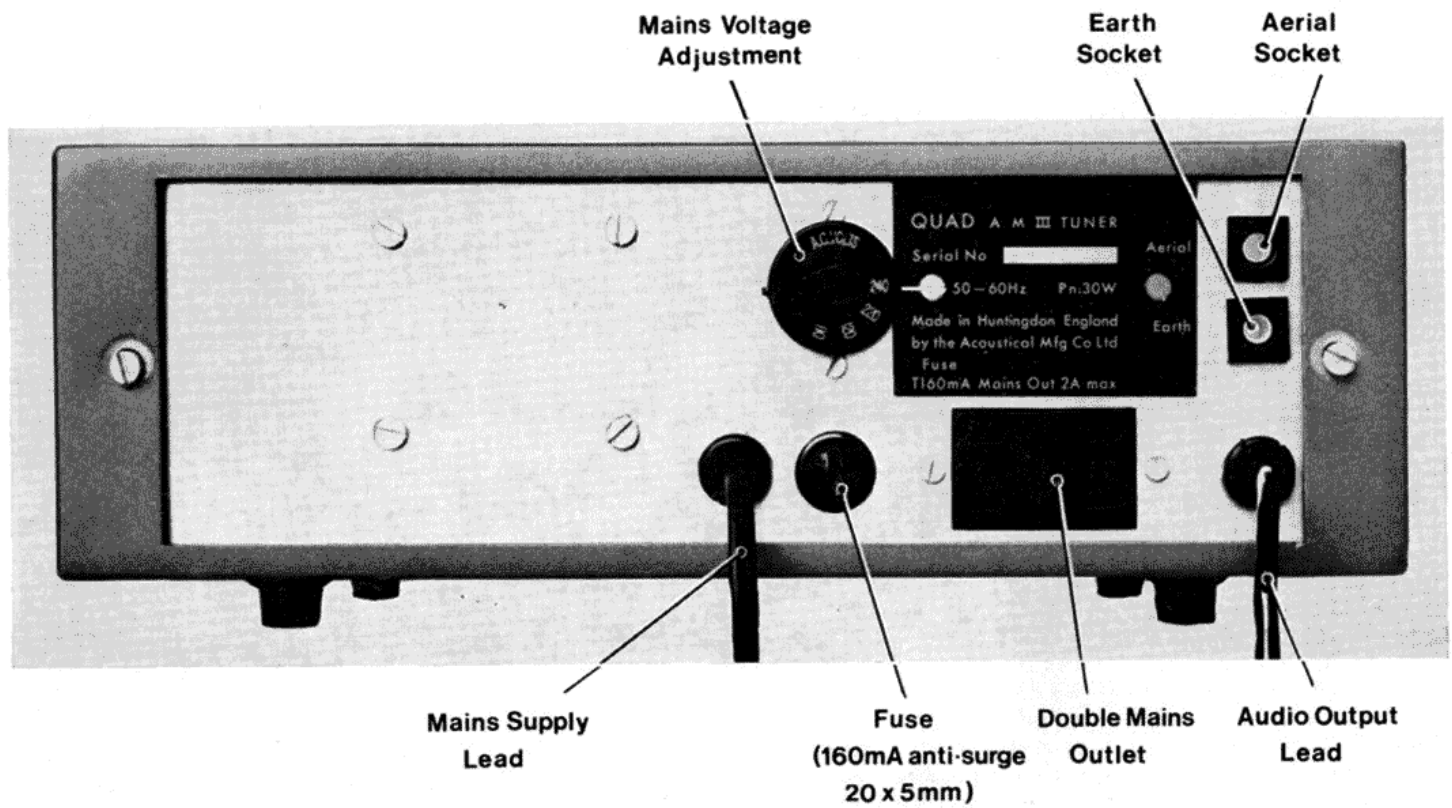

Fig. 1 Rear panel view

Aerial

The Quad AM3 tuner will work from any aerial but for the best signal to noise ratio a good aerial is worth the trouble of installation. The following notes extracted from the BBC publication 'Aerials for Shortwave Reception' may prove helpful.

The simplest kind of aerial is a horizontal or sloping wire, or a vertical rod, as shown in Figs 2 and 3. Variants of this are the T and inverted L aerials (Figs 4 and 5). The main point to watch in rigging these aerials is to make them reasonably long and also to get them as high as possible above the ground and surrounding objects. A length of about thirty feet will suffice for a sloping or horizontal wire aerial, but something approaching a hundred feet would be better. A vertical rod aerial should be about fifteen feet long. For the lead-in from these aerials a single insulated wire or coaxial cable is equally suitable, but where matching transformers are supplied with a vertical rod aerial the manufacturers' instructions should be followed.

For simplicity, the aerials in Figs 2 to 6 are shown suspended between poles; where suitable supports exist on the site, for instance a tree or a chimney stack, they can of course be used instead.

A horizontal dipole aerial (Fig. 6) is more efficient but only to signals from transmitters roughly broadside on to the line of the aerial. To signals arriving from the end-on directions it is less efficient, as also it is on wavebands other than that for which it was designed. These disadvantages may be offset without losing the dipole advantage when required, by arranging, by means of a switch or otherwise, to convert the dipole to the T aerial (Fig. 7).

6

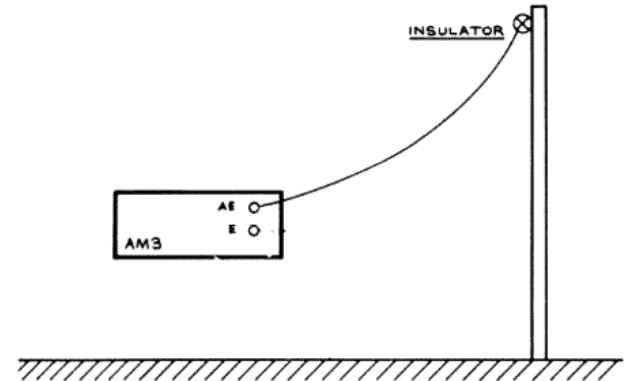

Fig. 2 Horizontal or sloping wire aerial

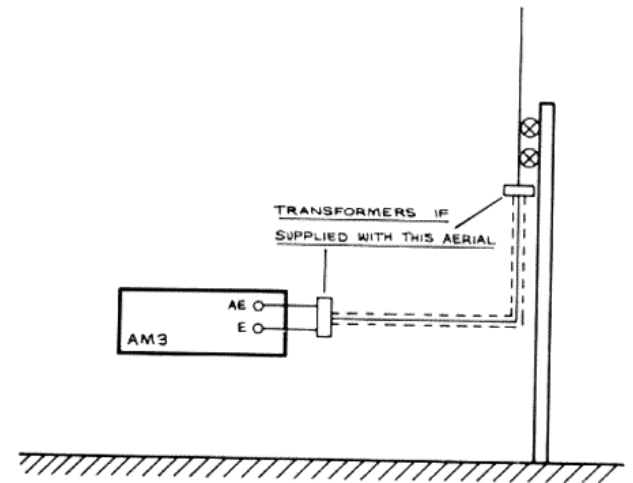

Fig. 3 Vertical rod aerial

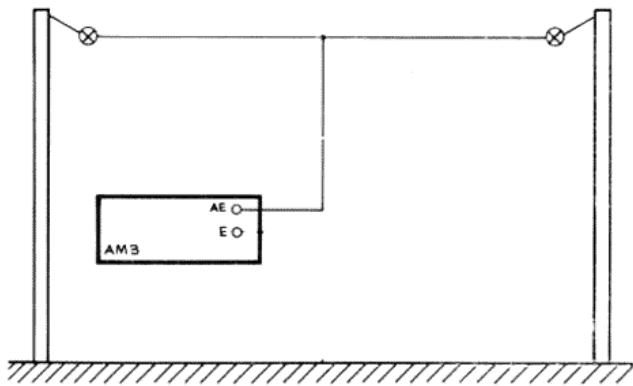

Fig. 4 T aerial

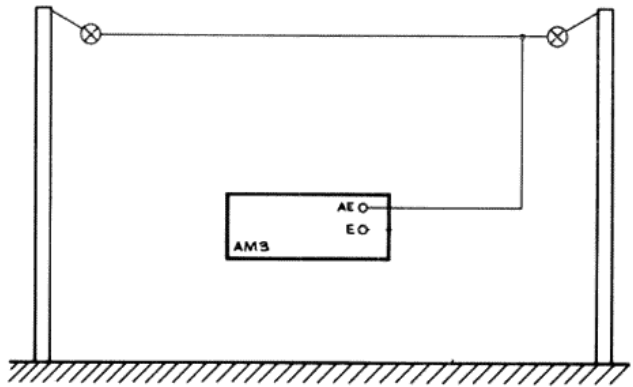

Fig. 5 Inverted L aerial

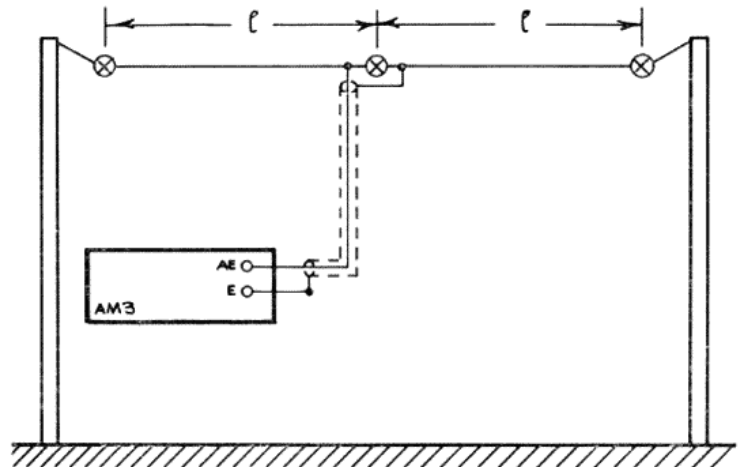

Fig. 6 Dipole aerial. A twin-wire feeder could be used instead of the co-axial cable shown

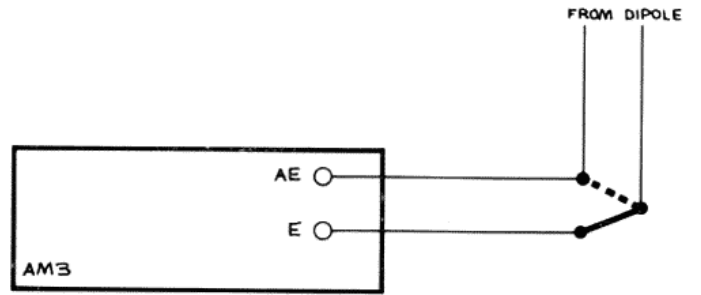

Fig. 7 Switch to convert a dipole aerial to a T aerial

Typical dimensions of each half (l) of a dipole aerial (see fig. 6)

Waveband	Frequency	Length (l) of each half of Dipole
<i>metres</i>	<i>MHz</i>	<i>feet</i>
16	17	13
19	15	15
25	11	20
31	9	25
41	7	33
49	6	38

Earth

Normally the earth connection of the whole installation already made to the terminal at the rear of the Quad 33 control unit precludes the need for a separate earth connection to the tuner but where a screened downlead is used the screening is connected to the earth socket. Where a matching transformer is supplied with the aerial the manufacturer's instructions should be followed.

Use with other amplifiers

As the tuner carries no on/off switch the mains supply should be switched either at the associated amplifier or by a separate switch.

The screening of the audio output signal lead is connected to chassis and will automatically bond the tuner to the associated amplifier so a separate mains earth connection is not required if the amplifier is already earthed.

The audio output connections are shown on p. 5. Pins 3 and 5 are strapped to provide the mono signal on either or both channels and the amplifier input should provide a sensitivity of 100mV with an input resistance of not less than 100K.

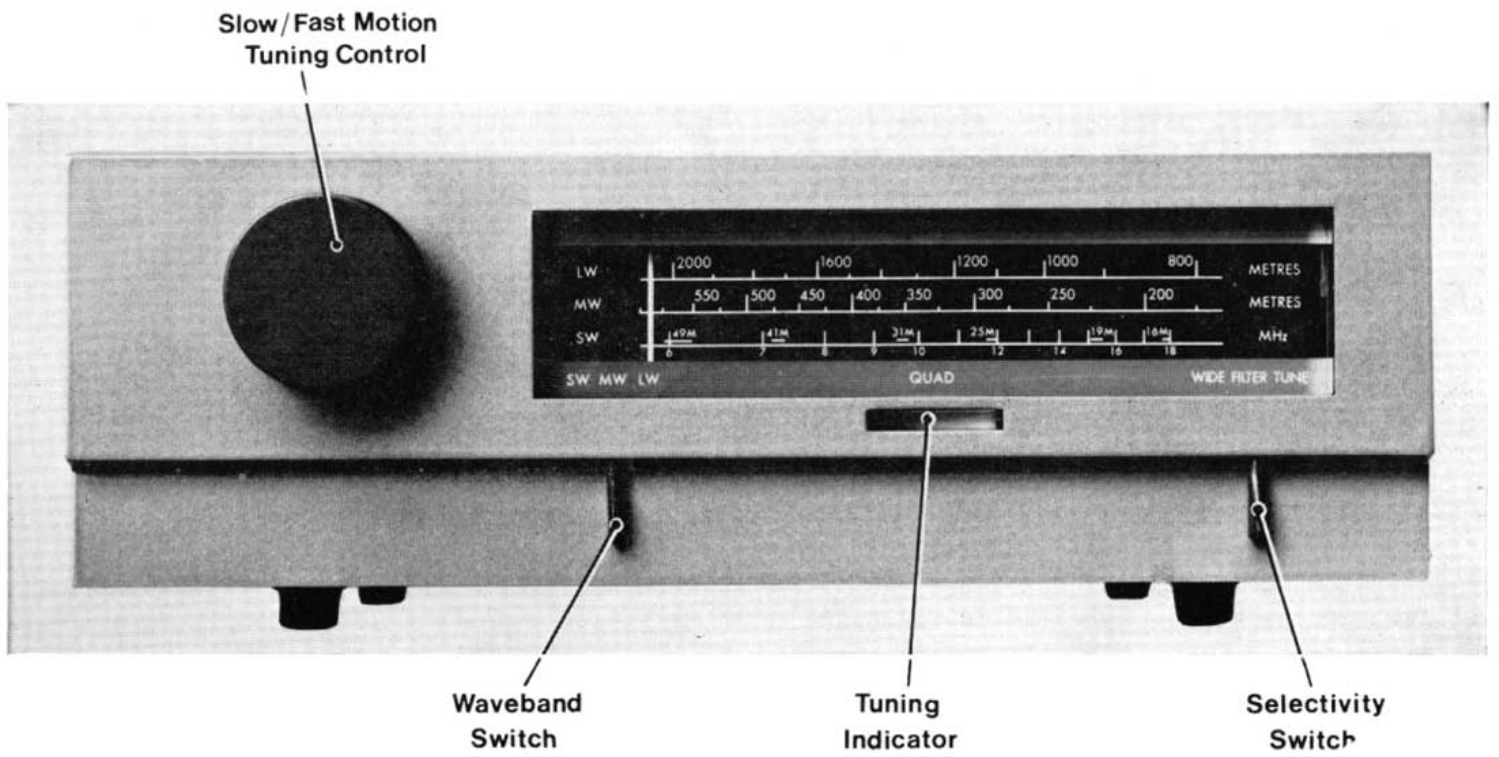

Fig. 8 Front panel view

OPERATION

Controls

There are three controls : Tuning, waveband switch, and selectivity switch.

Tuning

Set the selectivity switch to the Tune position so that the tuning indicator lights. After selecting the correct waveband, tune just past the station required. On reversing the direction of rotation, the slow motion drive will permit accurate adjustment. Adjust the tuning until the shadow between the two luminous bands of the indicator is at a minimum.

Accurate tuning cannot be obtained in the Filter or Wide positions of the selectivity switch, and the tuning indicator is therefore made inoperative in these positions.

Always switch to Tune before tuning.

Local Station Reception

Turn the selectivity switch to the Wide position in order to accept the full transmitted frequency range. If a high-pitched whistle is heard this may be eliminated by switching to the Filter position.

Sometimes, too, adjacent channel interference experienced in the Filter or Wide positions can be reduced by detuning slightly away from the interfering transmission, without greatly affecting the wanted signal. Under these conditions such detuning may well result in an overall improvement of reception.

(It should be noted, however that the true tuning position remains unaffected in spite of this audible improvement which is also accompanied by some reduction in high frequency response and increased volume due to reduction of the AGC voltage).

Distant Station Reception

The Tune selectivity position will normally give the more acceptable results although, if reception conditions are good, better quality may be obtainable in the Filter position.

If reception is very poor a considerable improvement may be effected by use of the 5K variable slope filter on the Quad 33 control unit.

CIRCUIT DETAIL

The aerial is transformer coupled to a variable- μ RF amplifier pentode (EF89) the anode circuit of which is transformer coupled to the mixer grid. Both grid circuits are tuned on all wavebands, and the Q of the medium wave circuits is reduced when switched to select a wideband response.

A triode heptode (ECH81) is used as the local oscillator and mixer. The oscillator anode circuit is tuned, and it is tracked by high-stability close-tolerance capacitors.

The 470 kHz output from the mixer anode is transformer coupled to the IF amplifier. The coupling is critical ($Q_k=1$) in the narrow band (Tune) condition. In the wide band condition the coupling is increased ($Q_k=4$) by including a

tertiary winding, thus ensuring that the response remains symmetrical about the centre frequency.

The IF amplifier is the pentode section of a double diode pentode (EBF 89). This valve has a high slope combined with a low anode-grid capacitance and allows a high stage gain without tilting the response within the IF pass band.

One diode of the EBF 89, with a small delay voltage applied, is used to provide the AGC voltage. This voltage is applied fully to the RF and mixer stages, and partially to the IF stage. The AGC circuit provides good control and large input signals are accepted without overload.

The IF amplifier anode is transformer coupled to the diode signal rectifier. The loaded Q of this transformer is half that of the first IF transformer and the coupling is critical. In the wide-band condition the combined IF response is within ± 1 dB to 12 kHz and in the narrow-band condition it is -3 dB at 3.5 kHz. In the 'Filter' position of the selectivity switch a bridged-T rejection circuit tuned to the adjacent channel heterodyne whistle is combined with the wide-band response.

The audio output is taken from a small fraction of the diode load in order to minimise distortion with heavily modulated input signals.

The tuning indicator (EM 84) has a variable- μ characteristic and will give a clear indication of the correct tuning point over a wide range of input signal levels. The greatest accuracy of indication is given when the IF amplifier has a narrow pass band. The indicator is therefore made in-operative in the wide-band switch positions.

ALIGNMENT INSTRUCTIONS

Each set is fully aligned before despatch and this procedure is intended only for subsequent re-alignment should it become necessary. No departure from this procedure is permissible and the work should be undertaken only by a competent radio service engineer.

AF Alignment

Power supplies are not required for this adjustment and the tuner should not be connected to the control unit.

Connect an AF signal generator between the junction C41, R20 and earth. Connect a sensitive AC valve voltmeter or oscilloscope across tuner output. Adjust signal generator to give about 10 volts at exactly 9 kHz (or 10 kHz on Overseas tuners). With selectivity switch to Filter adjust L10 and RV1 for minimum output (to be less than 5mV).

IF Alignment

Preliminary. Plug audio lead into control unit, then mains lead. Wave-change switch to SW (or SW2 on Overseas tuners). Selectivity switch to Narrow. Tuning capacitor to maximum capacity. Short-circuit C29. Short-circuit C31. Short-circuit C33. Connect 0-50 μ A DC meter in series with R23. Unscrew the IF transformer tuning cores until they project slightly from the formers.

The correct tuning point is the first one reached when the core is screwed in.

During the IF and RF alignment the output of the RF signal generator should be adjusted to produce about half scale deflection of the output current micro-ammeter.

A damping resistor of 10,000 ohms is used during the alignment procedure. The mains supply should be switched off when handling this resistor.

- (1) Apply 470 kHz signal to EBF89 grid (V3 pin 2). Connect damping resistor across IFT2 primary. Adjust IFT2 secondary (top core) for maximum output current.
- (2) Transfer damping resistor to IFT2 secondary. Adjust IFT2 primary (bottom core) for maximum output current.
- (3) Repeat (1) and (2) until there is no further improvement in output.
- (4) Apply 470 kHz signal to ECH81 grid (V2 pin 2). Connect damping resistor across IFT1 primary. Adjust IFT1 secondary (top core) for maximum output current.
- (5) Transfer damping resistor to IFT1 secondary. Adjust primary (bottom core) for maximum output current.
- (6) Repeat (4) and (5) until there is no further improvement in output.
- (7) Remove damping resistor. Check that response curve is symmetrical either side of 470 kHz.
- (8) With selectivity switch to Wide check that output current is equal at 459, 470 and 481 kHz, and that a rise of about 10% appears at 465 and 475 kHz.

RF Alignment (European Tuners)

Preliminary. Remove short-circuit from C29. Check that pointer lies at 588m when tuning capacitor is at maximum. Selectivity switch to Narrow. Connect RF signal generator to Aerial and Earth sockets via dummy aerial. The correct tuning point for L1, L2, L4, L5, L7, L8 is with the core nearest the mounting base of the coil.

- (1) Switch to LW. Set tuner to 2,000 m and signal generator to 150 kHz. Adjust core of L7, then L4, then L1 for maximum output current.
- (2) Set tuner to 1,000 m and signal generator to 300 kHz. Adjust C25, then C11, then C1 for maximum output current.
- (3) Repeat (1) and (2) until there is no improvement in output current.
- (4) Switch to MW. Set tuner to 525m and signal generator to 572 kHz. Adjust core of L8, then L5, then L2 for maximum output current.
- (5) Set tuner to 200m and signal generator to 1,500 kHz. Adjust C26, then C12, then C2 for maximum output current.
- (6) Repeat (4) and (5) until there is no improvement in output current. Finish on (5).
- (7) Set signal generator to 1,000 kHz, tune in signal and check that calibration is correct (300 m).
- (8) Switch to SW. Set tuner to 6.5 MHz and signal generator to 6.5 MHz. Adjust L9, then L6, then L3 for maximum output current. Set signal generator to 7.44 MHz, increase signal generator output and check that image frequency is received with tuner set to 6.5 MHz.

- (9) Set tuner to 17 MHz and signal generator to 17 MHz. Adjust C27, then C13, then C3 for maximum output current. Alignment of C13 and C3 may be assisted by rocking the ganged capacitor slightly. Set signal generator to 17.94 MHz, increase signal generator output and check that image frequency is received with tuner set to 17 MHz.
- (10) Repeat (8) and (9) until there is no improvement in output current, Finish on (9).
- (11) Set signal generator to 12 MHz, tune in signal, and check that calibration is correct.
- (12) Remove micro-ammeter and reconnect R23. Remove short-circuit from C31 and C33.
- (4) Set signal generator to 1,000 kHz, tune in signal and check that calibration is correct.
- (5) Switch to SW1. Set tuner and signal generator to 2.5 MHz. Adjust core of L13, then L12, then L11 for maximum output current.
- (6) Set tuner and signal generator to 6.25 MHz. Adjust C26, then C12, then C2 for maximum output current.
- (7) Repeat (5) and (6) until there is no improvement in output current, Finish on (6).
- (8) Set signal generator to 4.0 MHz, tune in signal and check that calibration is correct.
- (9) Switch to SW2. Set tuner to 6.5 MHz and signal generator to 6.5 MHz. Adjust L9, then L6, then L3 for maximum output current. Set signal generator to 7.44 MHz, increase signal generator output and check that image frequency is received with tuner set to 6.5 MHz.

RF Alignment (Overseas Tuners)

Preliminary. Remove short-circuit from C29. Check that pointer lies at 510 kHz when tuning capacitor is at maximum. Selectivity switch to Narrow. Connect RF signal generator to Aerial and Earth sockets via dummy aerial. The correct tuning point for L2, L5, L8, L11, L12, L13 is with the core nearest the mounting base of the coil.

- (1) Switch to MW. Set tuner to 572 kHz (this coincides with the 6.5 MHz mark on the SW2 scale). Set signal generator to 572 MHz. Adjust core of L8, then L5, then L2 for maximum output current.
- (2) Set tuner and signal generator to 1,500 kHz. Adjust C25, then C11, then C1 for maximum output current.
- (3) Repeat (1) and (2) until there is no improvement in output current. Finish on (2).
- (10) Set tuner to 17 MHz and signal generator to 17 MHz. Adjust C27, then C13, then C3 for maximum output current. Alignment of C13 and C3 may be assisted by rocking the ganged capacitor slightly. Set signal generator to 17.94 MHz, increase signal generator output and check that image frequency is received with tuner set to 17 MHz.
- (11) Repeat (9) and (10) until there is no improvement in output current. Finish on (10).
- (12) Set signal generator to 12 MHz, tune in signal, and check that calibration is correct.
- (13) Remove micro-ammeter and reconnect R15. Remove short-circuit from C31 and C33.

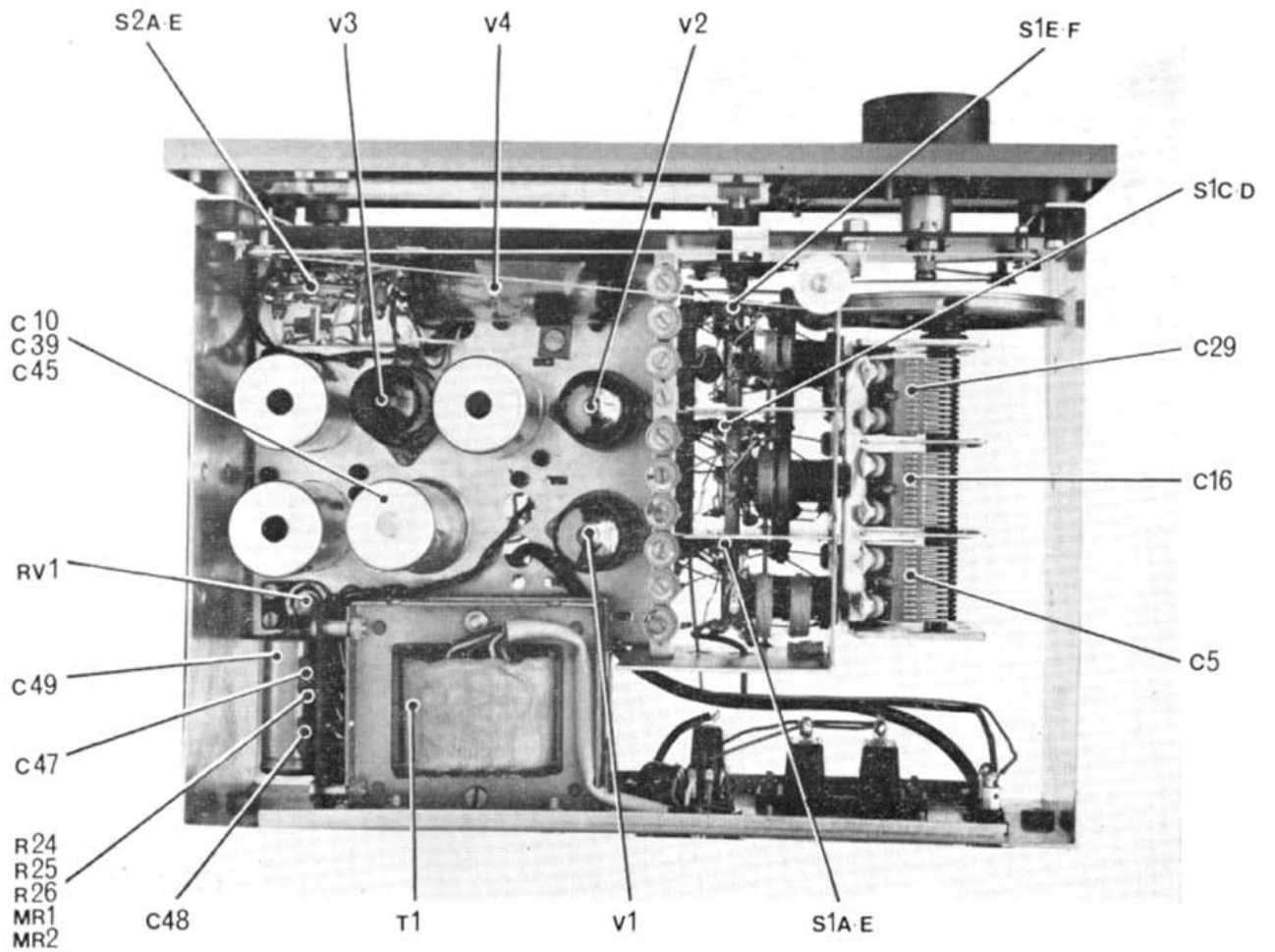

Fig. 9 Above chassis view

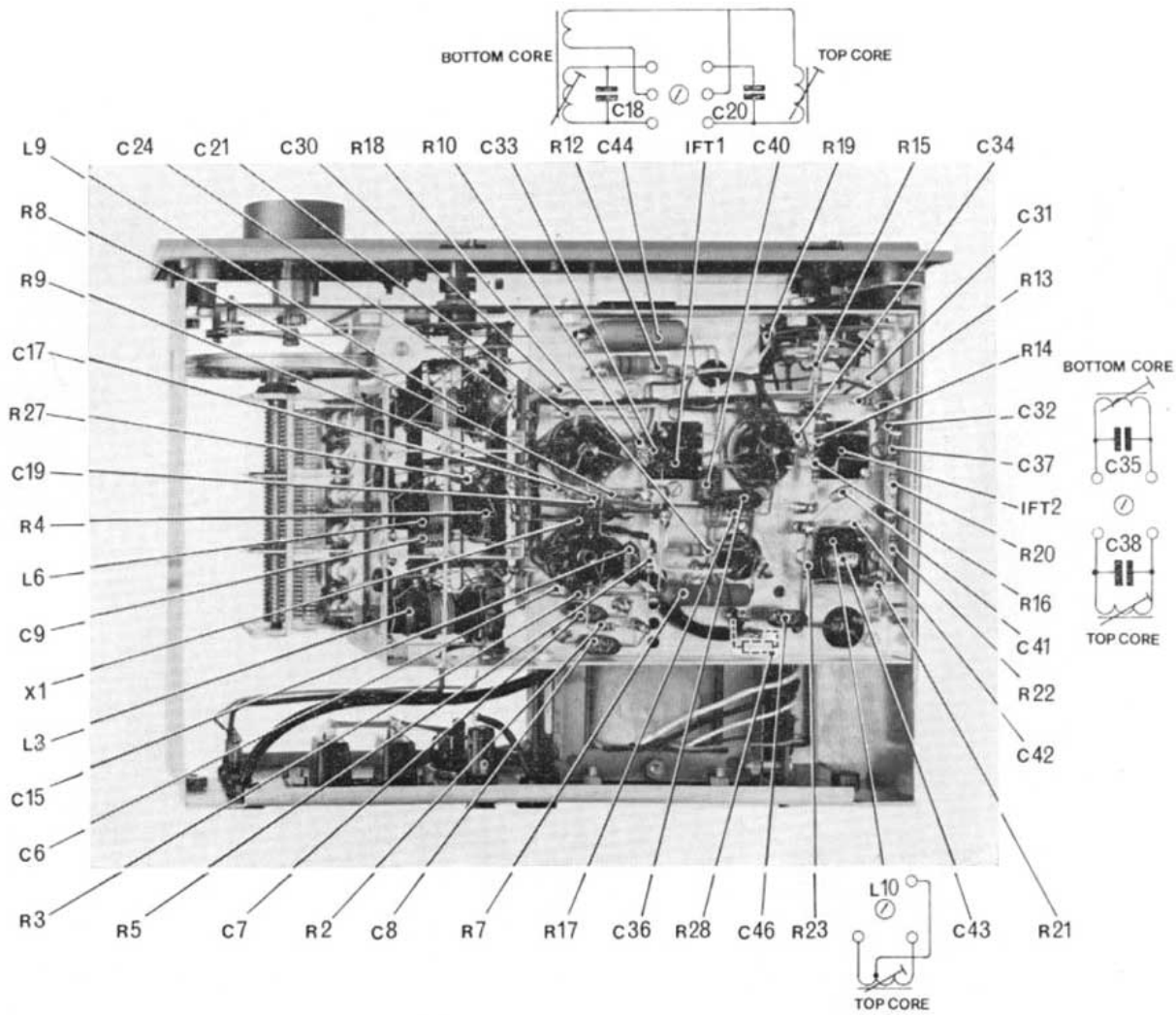

Fig. 10 Under chassis view

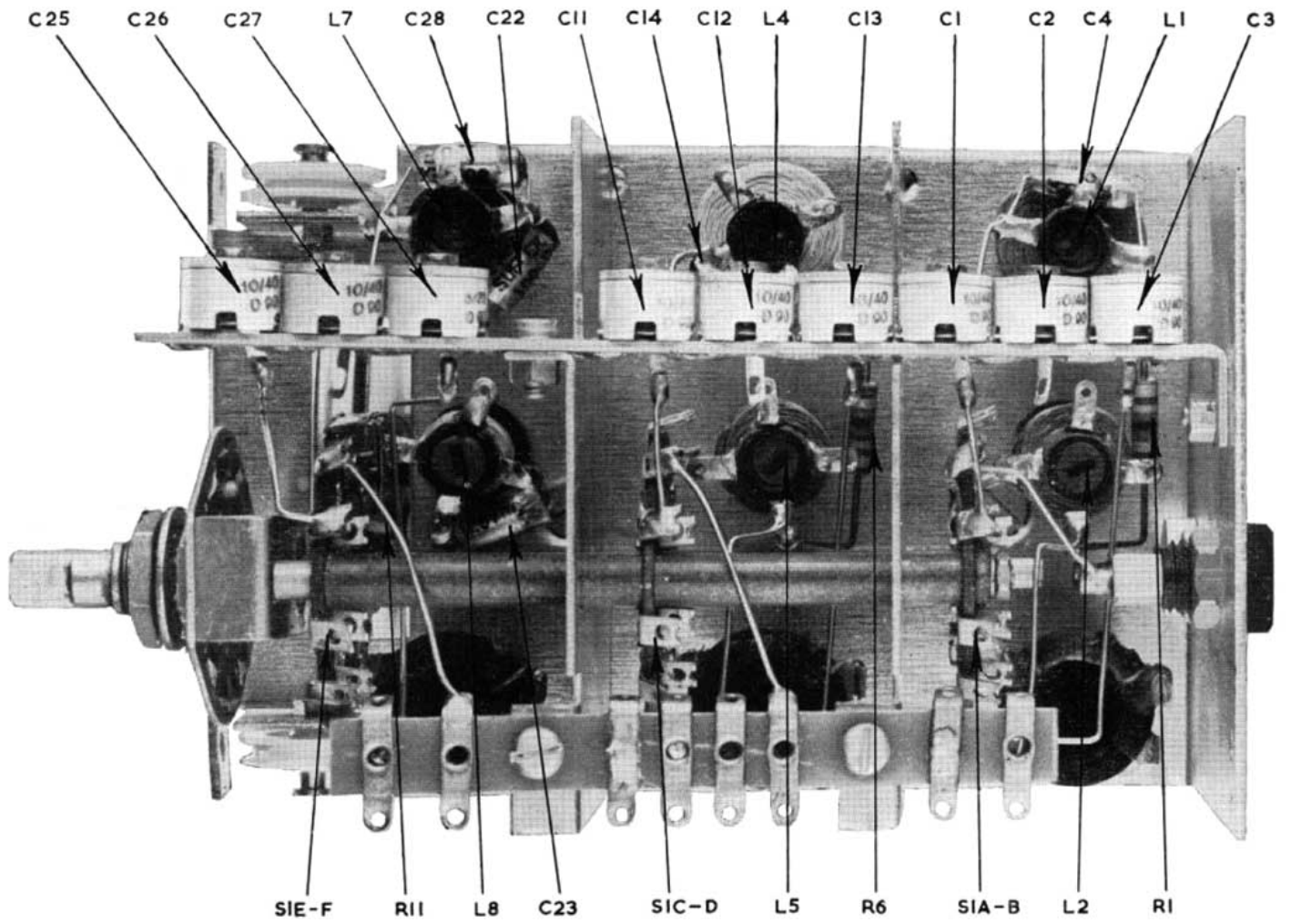

Fig. 11 R. F. chassis—European model

The drive cord runs from the upper pulley to the rear of the slow motion drive capstan, then $2\frac{3}{4}$ turns around the capstan in a forward direction, and off to the lower pulley.

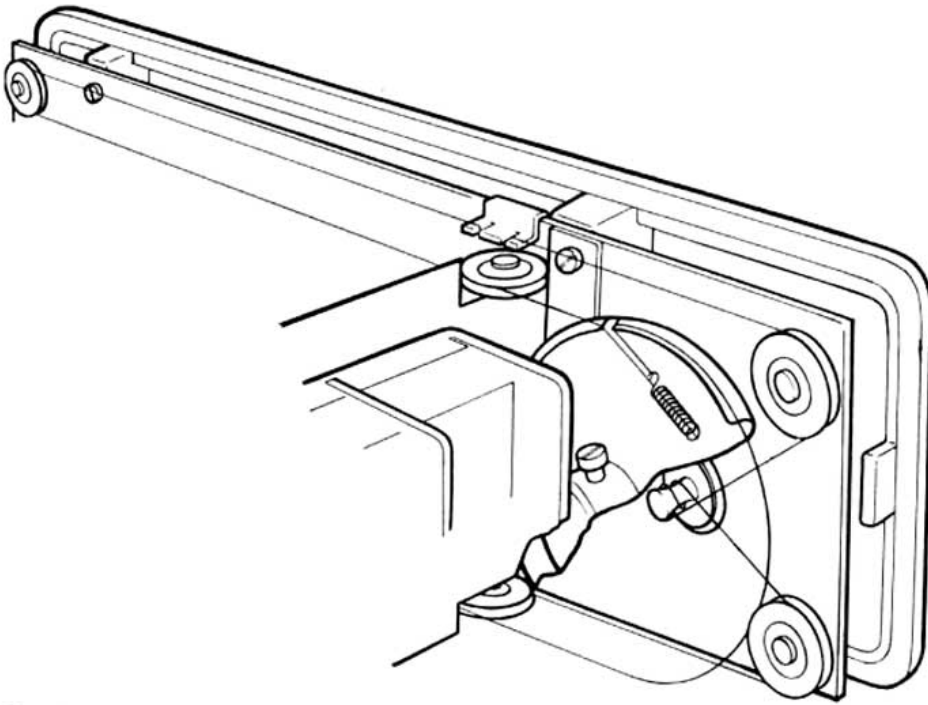

Fig. 13 Replacing the drive cord
18

Specification

Tuning range:

AM3/European

Long wave: 2070-800 metres (145-375 kHz)

Medium wave: 588-185 metres (510-1620 kHz)

Short wave: 5.8-18.5 MHz (52-16.2 metres)

AM3/Overseas

Medium wave: 510-1620 kHz (588-185 metres)

Shortwave 1: 2.2-6.6 MHz (136-45 metres)

Shortwave 2: 5.8-18.5 MHz (52-16.2 metres)

IF Frequency 470 kHz

Output level: 100mV (Nominal for 30% modulation)

Output resistance: 15,000 ohms

Filter rejection frequency: AM3/European: 9 kHz

AM3/Overseas: 10 kHz

Power requirement: 100-130 or 200-250 Volts AC

50-60 Hz 25 Watts

Power and Signal cable lengths: 4 feet (120 cm)

Valve complement: EF 89, ECH 81, EBF 89, EM 84.

Dimensions:

Width 10 $\frac{1}{4}$ " (260 mm)

Height 3 $\frac{5}{8}$ " (92 mm) free standing

3 $\frac{1}{4}$ " (83 mm) panel

Depth 8" (200 mm) free standing

7 $\frac{1}{8}$ " (180 mm) behind cabinet panel when mounted

(allow up to a further 1" (25 mm) for connections depending on panel thickness)

Weight: 8 lbs (3.5 Kg)

GUARANTEE

This instrument is guaranteed against any defect in material or workmanship for a period of twelve calendar months from the date of purchase.

Within this period we undertake to supply replacements free of charge for any parts which may prove on examination to be defective provided that such defectiveness is not the result of misuse (including use with unsuitable ancillary equipment), accident or negligence, and further that the instrument was purchased at the proper retail price prevailing in the country of purchase.

Any set requiring service under this guarantee should be taken to the supplier through whom it was purchased, or, in case of difficulty, it should be carefully packed and consigned, carriage paid to the main distributor for the country of purchase quoting the date and place of purchase. It must not be sent to any other agent or distributor except by special arrangement.

This guarantee is valid only when these conditions are complied with and does not cover labour or carriage costs involved in any repair under the guarantee.

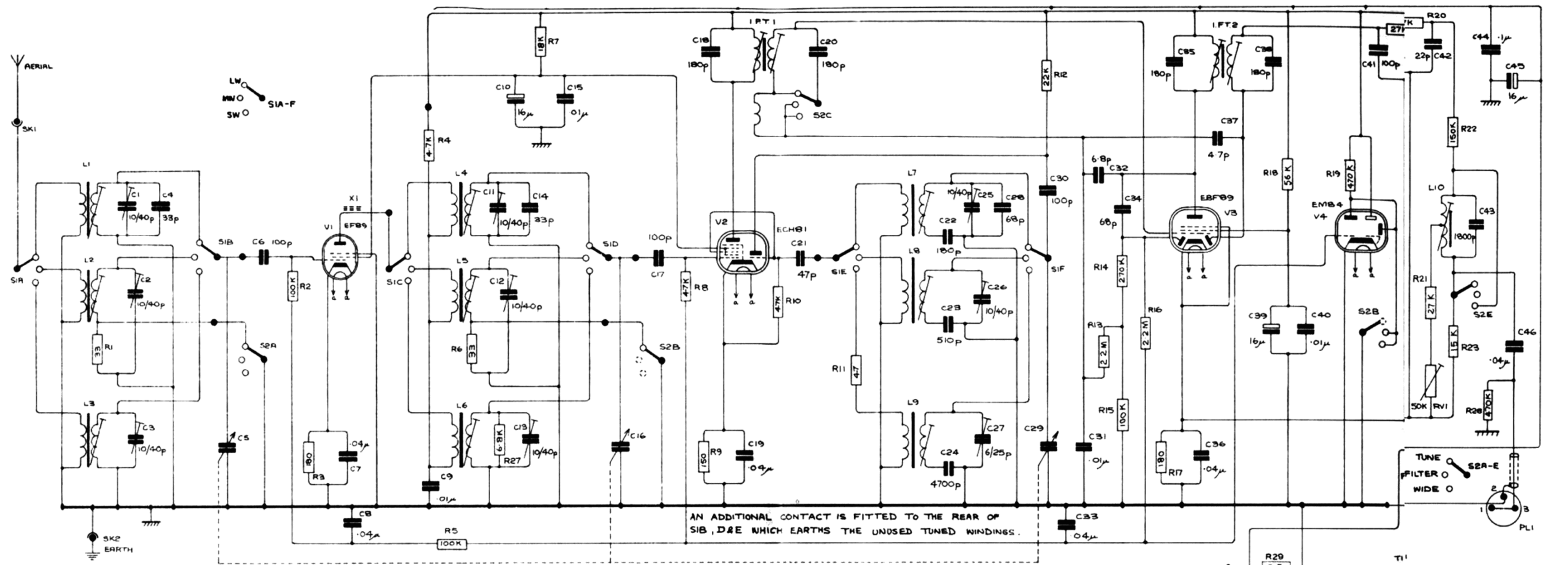

REF	VALUE	TOL.	MINIERS	REFERENCE	STOCK NO.	REF	VALUE	TOL.	MINIERS	REFERENCE	STOCK NO.
R1	50K	±0.5%	ISARR	UPM 1/4W	344/A	C11	1000p		STARTITE 10 S-TUNO 07 10/40 D90	854/A	
R2	200K	±0.5%	ISARR	UPM 1/4W	300/A	C12	1000p		STARTITE 10 S-TUNO 07 10/40 D90	854/A	
R3	180K	±0.5%	ISARR	UPM 1/4W	300/B	C13	1000p		STARTITE 10 S-TUNO 07 10/40 D90	854/A	
R4	47K	±0.5%	ISARR	UPM 1/4W	240/F	C14	1000p		LEMO 7x3 mm	537/A	
R5	200K	±0.5%	ISARR	UPM 1/4W	240/A	C15	100p		HUNTS BD21	504/C	
R6	93K	±0.5%	ISARR	UPM 1/4W	344/B	C16	200p		ACOUSTICAL DRG No A11490 152 WITH C5 & C29	554/A	
R7	100K	±0.5%	ERE	100R	220/A	C17	100p		LEMO 7x5 mm	529/A	
R8	57K	±0.5%	ISARR	UPM 1/4W	300/F	C18	100p		LEMO 7x5 mm	527/A	
R9	150K	±0.5%	ISARR	UPM 1/4W	290/B	C19	100p		LEMO 7x5 mm	501/A	
R10	47K	±0.5%	ISARR	UPM 1/4W	200/F	C20	100p		HUNTS BD16	512/A	
R11	47K	±0.5%	SARR	UPM 1/4W	310/F	C21	47p		LEMO 7x5 mm	538/A	
R12	200K	±0.5%	ISARR	UPM 1/4W	307/A	C22	100p		LEMO 7x5 mm	527/B	
R13	2.2M	±0.5%	ISARR	UPM 1/4W	57/D	C23	50p		LEMO 7x5 mm	522/A	
R14	27K	±0.5%	ISARR	UPM 1/4W	180/F	C24	470p		LEMO 20x10 mm	516/A	
R15	100K	±0.5%	ISARR	UPM 1/4W	200/B	C25	100p		STARTITE 10 S-TUNO 07 10/40 D90	554/A	
R16	2.2M	±0.5%	ISARR	UPM 1/4W	57/D	C26	100p		STARTITE 10 S-TUNO 07 10/40 D90	554/A	
R17	180K	±0.5%	ISARR	UPM 1/4W	180/B	C27	47p		STARTITE 10 S-TUNO 07 10/40 D90	554/A	
R18	50K	±0.5%	ISARR	UPM 1/4W	304/A	C28	100p		LEMO 7x5 mm	504/A	
R19	470K	±0.5%	ISARR	UPM 1/4W	76/C	C29	50p		ACOUSTICAL DRG No A11490 152 WITH C5 & C16	554/B	
R20	27K	±0.5%	ISARR	UPM 1/4W	200/D	C30	100p		LEMO 7x5 mm	504/B	
R21	150K	±0.5%	ISARR	UPM 1/4W	101/D	C31	100p		HUNTS BD21	504/C	
R22	150K	±0.5%	ISARR	UPM 1/4W	101/B	C32	4.7p		ERE PROO	504/D	
R23	15K	±0.5%	ISARR	UPM 1/4W	224/C	C33	4.7p		HUNTS BD16	501/A	
R24	1K	±0.5%	ISARR	UPM 1/4W	258/E	C34	4.7p		LEMO 7x5 mm	524/A	
R25	1K	±0.5%	ISARR	UPM 1/4W	218/E	C35	100p		LEMO 7x5 mm	527/A	
R26	470K	±0.5%	ISARR	UPM 1/4W	170/B	C36	100p		HUNTS BD16	501/A	
R27	50K	±0.5%	ISARR	UPM 1/4W	255/B	C37	4.7p		ERE PROO	504/D	
R28	470K	±0.5%	ISARR	UPM 1/4W	76/C	C38	100p		LEMO 7x5 mm	527/A	
R29	10.5	±5%	AMC	3W	334/A	C39	4.7p		HUNTS BD16 WITH C10 & C45	540/B	
C1	100p		STARTITE 10 S-TUNO 07 10/40 D90	854/A	C40	0.1u		HUNTS BD16	504/C		
C2	100p		STARTITE 10 S-TUNO 07 10/40 D90	854/A	C41	100p		LEMO 7x5 mm	529/A		
C3	100p		STARTITE 10 S-TUNO 07 10/40 D90	854/A	C42	22p		LEMO 7x3 mm	543/B		
C4	30p	±5%	LEMO 7x3 mm	537/A	C43	100p		LEMO 10x8 mm	515/B		
C5	50p		ACOUSTICAL DRG No A11490 152 WITH C16 & C29	554/A	C44	1u		MULLARD C306AC/100K	457/A		
C6	100p		LEMO 7x5 mm	537/A	C45	1u		HUNTS BD16 WITH C10 & C39	543/B		
C7	0.01		HUNTS BD16	501/A	C46	0.01		HUNTS BD16	501/A		
C8	0.01		HUNTS BD16	501/A	C47	1000p		ERE AP K3000/AP II	514/F		
C9	0.1u		HUNTS BD21	504/C	C48	1000p		ERE AP K3000/AP II	514/F		
C10	10u		HUNTS KDQ405H WITH C35 & C45	460/B	C49	32u		HUNTS 3P25BRT	740/B		

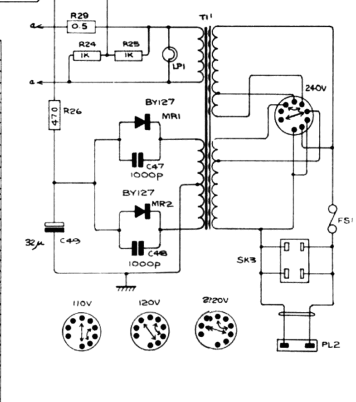

QUAD AM3 TUNER (European)

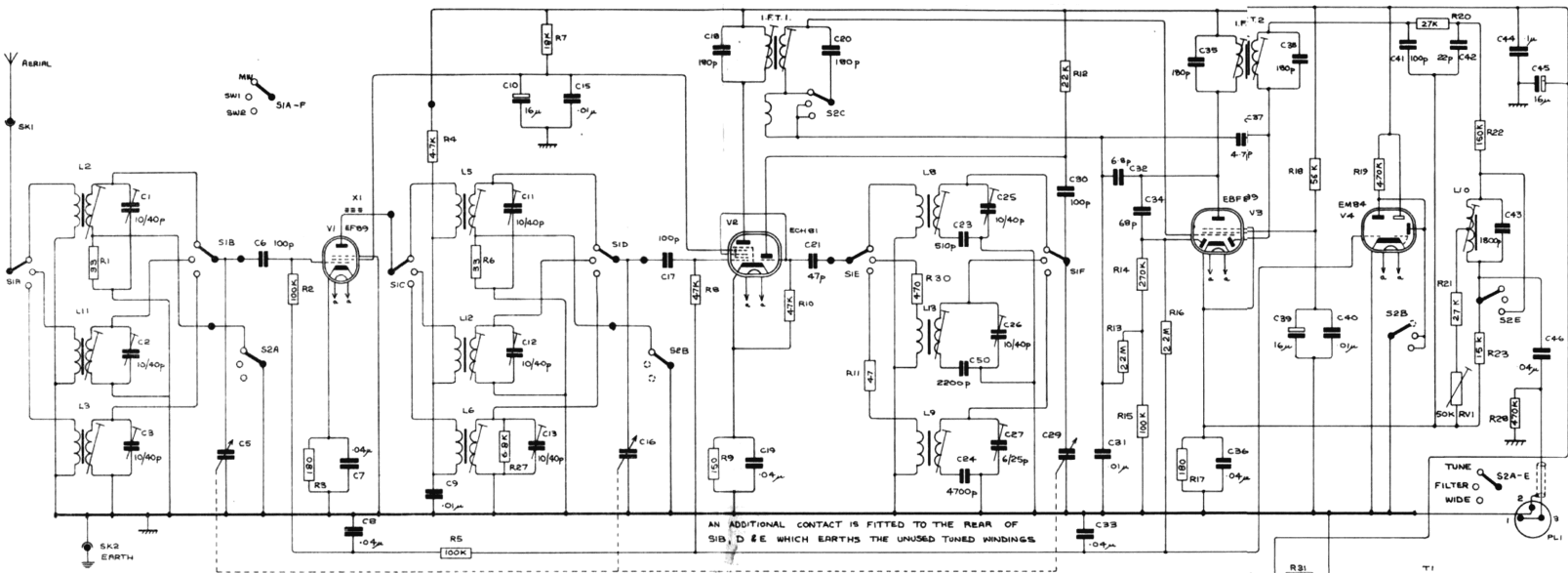

REF	VALUE	TOL	MAKERS	REFERENCE	STOCK No.	REF	VALUE	TOL	MAKERS	REFERENCE	STOCK No.
R1	33k	±10%	ISKRA	UPM 1/4W	314/M	R11	47k	±10%	ISKRA	UPM 1/4W	314/M
R2	100k	±10%	ISKRA	UPM 1/4W	200/M	R12	100k	±10%	ISKRA	UPM 1/4W	200/M
R3	180k	±10%	ISKRA	UPM 1/4W	290/D	R13	27k	±10%	ISKRA	UPM 1/4W	314/M
R4	27k	±10%	ISKRA	UPM 1/4W	290/D	R14	150k	±10%	ISKRA	UPM 1/4W	200/M
R5	100k	±10%	ISKRA	UPM 1/4W	200/M	R15	150k	±10%	ISKRA	UPM 1/4W	200/M
R6	33k	±10%	ISKRA	UPM 1/4W	314/M	R16	27k	±10%	ISKRA	UPM 1/4W	314/M
R7	18k	±10%	ISKRA	UPM 1/4W	200/M	R17	180k	±10%	ISKRA	UPM 1/4W	290/D
R8	47k	±10%	ISKRA	UPM 1/4W	314/M	R18	100k	±10%	ISKRA	UPM 1/4W	200/M
R9	150k	±10%	ISKRA	UPM 1/4W	290/D	R19	100k	±10%	ISKRA	UPM 1/4W	200/M
R10	47k	±10%	ISKRA	UPM 1/4W	314/M	R20	100k	±10%	ISKRA	UPM 1/4W	200/M
R11	47k	±10%	ISKRA	UPM 1/4W	314/M	R21	100k	±10%	ISKRA	UPM 1/4W	200/M
R12	22k	±10%	DISBUR	BTA	27/B	R22	150k	±10%	ISKRA	UPM 1/4W	290/D
R13	27k	±10%	ISKRA	UPM 1/4W	314/M	R23	150k	±10%	ISKRA	UPM 1/4W	290/D
R14	270k	±10%	ISKRA	UPM 1/4W	193/R	R24	150k	±10%	ISKRA	UPM 1/4W	290/D
R15	100k	±10%	ISKRA	UPM 1/4W	200/M	R25	150k	±10%	ISKRA	UPM 1/4W	290/D
R16	27k	±10%	ISKRA	UPM 1/4W	314/M	R26	150k	±10%	ISKRA	UPM 1/4W	290/D
R17	180k	±10%	ISKRA	UPM 1/4W	290/D	R27	150k	±10%	ISKRA	UPM 1/4W	290/D
R18	100k	±10%	ISKRA	UPM 1/4W	200/M	R28	150k	±10%	ISKRA	UPM 1/4W	290/D
R19	47k	±10%	ISKRA	UPM 1/4W	314/M	R29	150k	±10%	ISKRA	UPM 1/4W	290/D
R20	100k	±10%	ISKRA	UPM 1/4W	200/M	R30	150k	±10%	ISKRA	UPM 1/4W	290/D
R21	27k	±10%	ISKRA	UPM 1/4W	314/M	R31	150k	±10%	ISKRA	UPM 1/4W	290/D
R22	150k	±10%	ISKRA	UPM 1/4W	290/D	R32	150k	±10%	ISKRA	UPM 1/4W	290/D
R23	150k	±10%	ISKRA	UPM 1/4W	290/D	R33	150k	±10%	ISKRA	UPM 1/4W	290/D
R24	150k	±10%	ISKRA	UPM 1/4W	290/D	R34	150k	±10%	ISKRA	UPM 1/4W	290/D
R25	150k	±10%	ISKRA	UPM 1/4W	290/D	R35	150k	±10%	ISKRA	UPM 1/4W	290/D
R26	150k	±10%	ISKRA	UPM 1/4W	290/D	R36	150k	±10%	ISKRA	UPM 1/4W	290/D
R27	150k	±10%	ISKRA	UPM 1/4W	290/D	R37	150k	±10%	ISKRA	UPM 1/4W	290/D
R28	150k	±10%	ISKRA	UPM 1/4W	290/D	R38	150k	±10%	ISKRA	UPM 1/4W	290/D
R29	150k	±10%	ISKRA	UPM 1/4W	290/D	R39	150k	±10%	ISKRA	UPM 1/4W	290/D
R30	150k	±10%	ISKRA	UPM 1/4W	290/D	R40	150k	±10%	ISKRA	UPM 1/4W	290/D
R31	150k	±10%	ISKRA	UPM 1/4W	290/D	R41	150k	±10%	ISKRA	UPM 1/4W	290/D
R32	150k	±10%	ISKRA	UPM 1/4W	290/D	R42	150k	±10%	ISKRA	UPM 1/4W	290/D
R33	150k	±10%	ISKRA	UPM 1/4W	290/D	R43	150k	±10%	ISKRA	UPM 1/4W	290/D
R34	150k	±10%	ISKRA	UPM 1/4W	290/D	R44	150k	±10%	ISKRA	UPM 1/4W	290/D
R35	150k	±10%	ISKRA	UPM 1/4W	290/D	R45	150k	±10%	ISKRA	UPM 1/4W	290/D
R36	150k	±10%	ISKRA	UPM 1/4W	290/D	R46	150k	±10%	ISKRA	UPM 1/4W	290/D
R37	150k	±10%	ISKRA	UPM 1/4W	290/D	R47	150k	±10%	ISKRA	UPM 1/4W	290/D
R38	150k	±10%	ISKRA	UPM 1/4W	290/D	R48	150k	±10%	ISKRA	UPM 1/4W	290/D
R39	150k	±10%	ISKRA	UPM 1/4W	290/D	R49	150k	±10%	ISKRA	UPM 1/4W	290/D
R40	150k	±10%	ISKRA	UPM 1/4W	290/D	R50	150k	±10%	ISKRA	UPM 1/4W	290/D
R41	150k	±10%	ISKRA	UPM 1/4W	290/D	R51	150k	±10%	ISKRA	UPM 1/4W	290/D
R42	150k	±10%	ISKRA	UPM 1/4W	290/D	R52	150k	±10%	ISKRA	UPM 1/4W	290/D
R43	150k	±10%	ISKRA	UPM 1/4W	290/D	R53	150k	±10%	ISKRA	UPM 1/4W	290/D
R44	150k	±10%	ISKRA	UPM 1/4W	290/D	R54	150k	±10%	ISKRA	UPM 1/4W	290/D
R45	150k	±10%	ISKRA	UPM 1/4W	290/D	R55	150k	±10%	ISKRA	UPM 1/4W	290/D
R46	150k	±10%	ISKRA	UPM 1/4W	290/D	R56	150k	±10%	ISKRA	UPM 1/4W	290/D
R47	150k	±10%	ISKRA	UPM 1/4W	290/D	R57	150k	±10%	ISKRA	UPM 1/4W	290/D
R48	150k	±10%	ISKRA	UPM 1/4W	290/D	R58	150k	±10%	ISKRA	UPM 1/4W	290/D
R49	150k	±10%	ISKRA	UPM 1/4W	290/D	R59	150k	±10%	ISKRA	UPM 1/4W	290/D
R50	150k	±10%	ISKRA	UPM 1/4W	290/D	R60	150k	±10%	ISKRA	UPM 1/4W	290/D
R51	150k	±10%	ISKRA	UPM 1/4W	290/D	R61	150k	±10%	ISKRA	UPM 1/4W	290/D
R52	150k	±10%	ISKRA	UPM 1/4W	290/D	R62	150k	±10%	ISKRA	UPM 1/4W	290/D
R53	150k	±10%	ISKRA	UPM 1/4W	290/D	R63	150k	±10%	ISKRA	UPM 1/4W	290/D
R54	150k	±10%	ISKRA	UPM 1/4W	290/D	R64	150k	±10%	ISKRA	UPM 1/4W	290/D
R55	150k	±10%	ISKRA	UPM 1/4W	290/D	R65	150k	±10%	ISKRA	UPM 1/4W	290/D
R56	150k	±10%	ISKRA	UPM 1/4W	290/D	R66	150k	±10%	ISKRA	UPM 1/4W	290/D
R57	150k	±10%	ISKRA	UPM 1/4W	290/D	R67	150k	±10%	ISKRA	UPM 1/4W	290/D
R58	150k	±10%	ISKRA	UPM 1/4W	290/D	R68	150k	±10%	ISKRA	UPM 1/4W	290/D
R59	150k	±10%	ISKRA	UPM 1/4W	290/D	R69	150k	±10%	ISKRA	UPM 1/4W	290/D
R60	150k	±10%	ISKRA	UPM 1/4W	290/D	R70	150k	±10%	ISKRA	UPM 1/4W	290/D

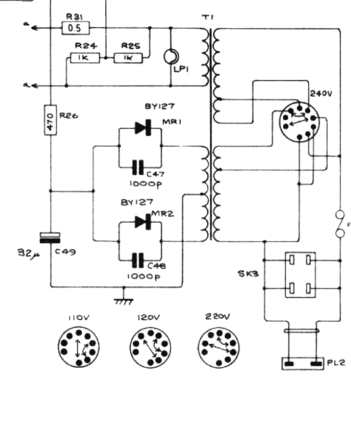

QUAD AM 3 TUNER (Overseas)